

Brushless DC Drives

Catalogue

January 2017



- Product overview 3

- BLP brushless DC drive**
 - Product description 4
 - Functions 5
 - Wiring example 13
 - Technical data 16
 - Dimensional drawings 17
 - Mechanical installation 19
 - Type code 20

- BLV brushless DC drive**
 - Product description 21
 - Functions 22
 - Wiring example 27
 - Technical data 28
 - Dimensional drawings 29
 - Mechanical installation 30
 - Type code 31

- Brushless DC motors**
 - Product Description 32
 - BDM 4•**
 - BDM 433 34
 - BDM 434 36
 - BDM 453 38
 - BDM 454 40
 - BDM 4• options**
 - BDM 4• with planetary gearbox PM42 42
 - BDM 4• type code 43

 - BDM 7•**
 - BDM 722 44
 - BDM 724 46
 - BDM 742 48
 - BDM 744 50
 - BDM 752 52
 - BDM 754 54
 - BDM 772 56
 - BDM 774 58

BDM 7• options	
BDM 7• with spur wheel gearbox	60
BDM 7• with planetary gearbox PM62.	61
BDM 7• with encoder.	62
BDM 7• with holding brake	64
BDM 7• type code.	67
Accessories	
Motor cable for BDM 4• motors.	68
GBX planetary gearboxes.	69
Annex	
Conversion tables.	71

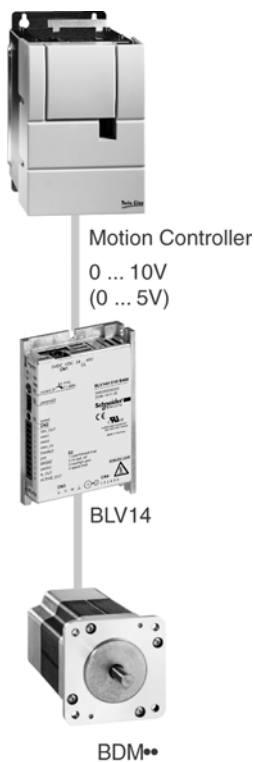
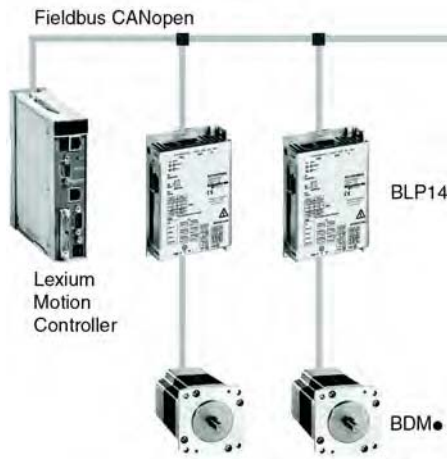

Product overview

Schneider Electric Motion brushless DC drive systems are an economical solution for many movement tasks. With compact and powerful motors and matching drives they offer a wide range of options in device technology and industrial automation.

Special features

Compactness

Brushless DC drive systems are noted for their very high efficiency. High output power and torque is available in small sizes. The advantage of the compact design is also applicable for the drives.

Flexibility

Brushless DC drives are available in two versions: BLP14 with CANopen fieldbus interface and BLV14 with analogue interface (5 V or 10 V). Both open-loop and closed loop operation is possible.

The motors are available in two sizes:

- BDM 4• with flange dimension 42 mm, in two lengths with nominal power from 56 to 95 W and nominal torque from 0.13 to 0.22 Nm.
- BDM 7• with flange dimension 66 mm, in four lengths with nominal power from 120 to 370 W and nominal torque from 0.24 to 0.8 Nm.

The brushless DC motors are fitted with Hall sensors as standard. For more accurate position detection the BDM 7• motors can be fitted with encoders. Motors are also available with planetary or spur wheel gear and holding brake.

Integrated safety function

BLP 14 integrates the "Safe Torque Off" safety function as per IEC/EN 61800-5-2. It enables an immediate stop by removal of power (i.e. an uncontrolled stop) without external power contactors. An unintended restart of the drive is impossible.

Economy

The use of Hall sensors for motor commutation and the cost-effective drive electronics result in a highly economical drive system.

Application options

The brushless DC motor technology is noted for its very long service life and functional safety. It is used if the performance of brush systems is not sufficient and also for servo applications in the lower power range.

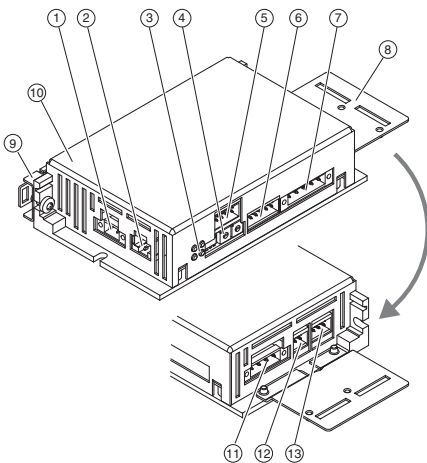

Product description

The BLP14 is a universal drive for controlling brushless DC motors. The BLP14 drives offers CANopen field bus connection or a ± 10 V analog input. Galvanic isolation of field bus and supply voltage ensures high system safety and reliability of installations. This allows for the integration of brushless DC drives into the standard field bus structures in industrial automation systems. In combination with the brushless DC motors of the BDM 4• and BDM 7• series they form an economical and powerful drive system.

Special features

- Interface for CANopen
- Compact design
- "Power Removal" safety function (Safe Torque Off "STO")

Device overview

- (1) Connection of power supply (CN1)
- (2) Connection of commissioning point (CN2)
- (3) LEDs for status display
- (4) Switches for making settings (S1, S2, S3)
- (5) Connection: Expanded I/O signal interface (CN4) (optional)
- (6) Connection of I/O signal interface (CN3)
- (7) Connection fieldbus interface (CN5)
- (8) EMC mounting plate (accessories)
- (9) DIN rail adapter (accessories)
- (10) Name plate
- (11) Connection of motor (CN6)
- (12) Connection of hall sensors (CN7)
- (13) Connection of motor encoder (CN8)

Control and interfaces

The BLP14 can control BSH brushless DC motors in accordance with a large number of control modes:

- Operating mode "Point-to-point": relative and absolute movements
- Operating mode "Current control"
- Operating mode "Speed control" with acceleration/deceleration ramp
- Operating mode "Profile velocity"
- Operating mode "Motion sequence"
- Manual movement for easy setup

The BLP14 has three control interfaces as standard:

- Interface for CANopen.
- One ± 10 V analog reference input to give the speed or current reference, and limit the speed or current.
- One interface to connect a motor encoder.

Functions

General overview of BLP14 functions

The BLP14 brushless DC drive integrates a large number of functions, enabling it to be used in a wide range of industrial applications.

There are two main function families:

Conventional adjustment functions

- Homing
- Jog
- Auto-tuning

Operating modes

- Current control
- Speed control
- Point-to-point mode
- Profile velocity
- Motion sequence

Types of operation

Two types of operation are possible:

- Local mode
- Fieldbus mode

In local mode

The drive parameters are defined via:

- The remote display terminal
- The Lexium CT commissioning software

Movements are then determined by:

- Analog signals (± 10 V)

In this mode, limit switches and homing switches are not managed by the brushless DC drive.

In fieldbus mode

All the brushless DC drive parameters and those associated with the operating modes can be accessed via:

- The fieldbus
- The remote display terminal
- The Lexium CT commissioning software

Conventional adjustment functions

Homing

Before performing an absolute movement in point-to-point mode, a homing operation must be carried out. Homing consists of associating an axis position with a known mechanical position. This position then becomes the reference position for any subsequent movement of the axis.

Homing is carried out by:

- Immediately writing the actual position register
- Movements up to a reference sensor

Homing with search for sensors

Four types of homing with movement to sensors are possible:

- Homing on - limit switch, "LIMN"
- Homing on + limit switch, "LIMP"
- Homing on reference contact "REF" with initial movement in negative direction of rotation
- Homing on reference contact "REF" with initial movement in positive direction of rotation

These homing movements can be performed with or without taking the "Zero marker" pulse into account.

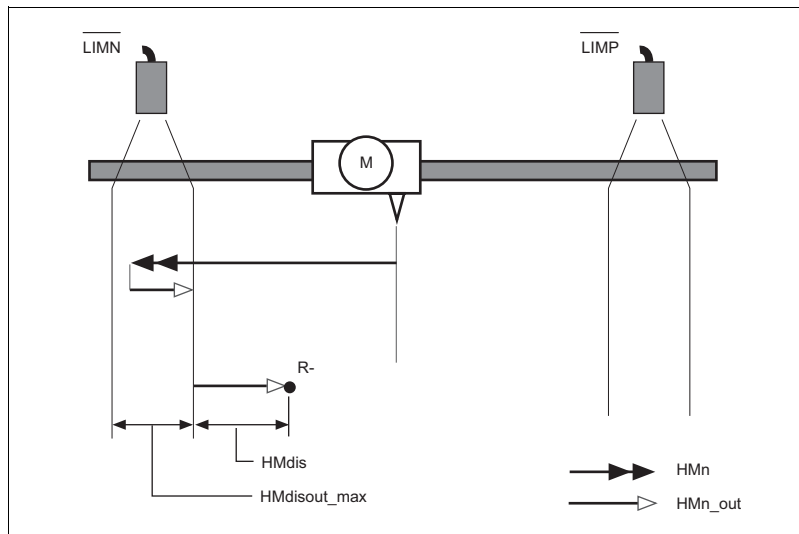

Homing operating mode: Example with limit switch "LIMN" and clearance from sensor edge

- (1) Move at search speed HMn
- (2) Move at output speed HMn_out
- (3) Clearance at distance HMdis at output speed HMn_out

Forced homing

Forced homing consists of setting the current motor position as the new reference point to which all subsequent positioning data refer.

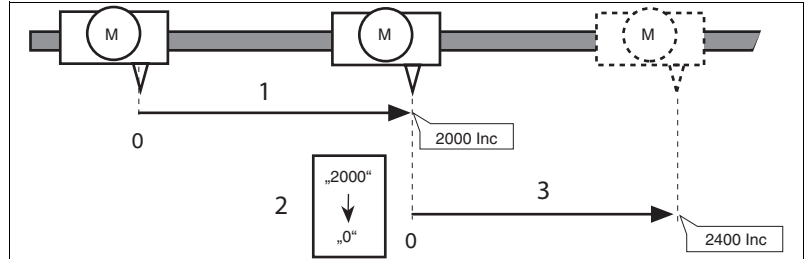

Forced homing operating mode

After power-up, the position value is 0.

- (1) Start movement towards the home point: the motor is positioned using a relative movement of 2000 increments.
- (2) Forced homing to value 0 by writing the actual position expressed in user units.
- (3) Initiation of a command to move 2400 increments to the absolute position. The target position is 2400 increments (4400 increments if forced homing had not been performed).

Homing parameters

The homing parameters are transmitted via the fieldbus or using Lexium CT commissioning software.

Jog

This mode enables an axis to be moved manually. The movement can be carried out over one movement step or continuously, at constant speed. Two speeds of movement are available (slow or fast). Various parameters are used to configure the manual movement.

Setpoint value

The parameters are transmitted via the fieldbus or the Lexium CT commissioning software.

With the start signal for the jog the motor first moves over a defined path unit. If the start signal is still pending after a specified wait period, the device switches to continuous operation until the start signal is canceled.

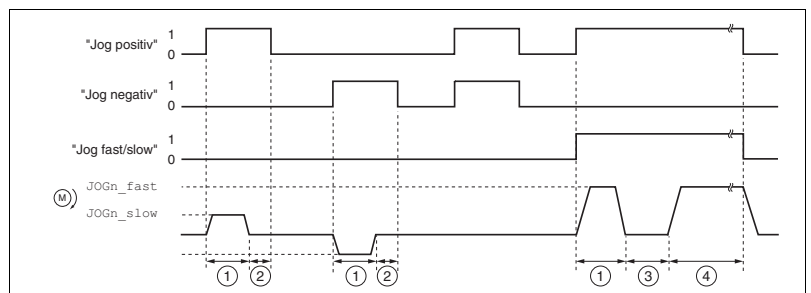

Adjustment of the machine in jog mode

- (1) Path unit
- (2) $t < \text{wait time}$
- (3) $t > \text{wait time}$
- (4) Continuous operation

Auto-tuning

The auto-tuning function integrated in the drive enables automatic tuning of the control parameters to be performed after the initial configuration.

This function is activated via:

- The remote display terminal
- The Lexium CT commissioning software

This procedure requires the motor to be coupled to its mechanism. Additional parameters can be used to limit the amplitude and the direction of the movements performed during the auto-tuning phase.

The Lexium CT commissioning software also provides screens for carrying out these drive control adjustments conventionally.

Operating modes

The following table summarizes the various possible operating modes, the control types and the sources of setpoint values.

Operating mode	in local control mode	in fieldbus control mode
Jog	digital inputs	digital inputs ¹⁾ / Fieldbus commands
Current control	analog input	analog input / Fieldbus commands
Speed control	analog input	analog input / Fieldbus commands
Point-to-point mode	-	Fieldbus commands
Profile velocity	-	Fieldbus commands
Motion sequence	digital inputs	digital inputs ¹⁾ / Fieldbus commands
Referencing	-	Fieldbus commands

¹⁾ optional

Current control

In the mode "Current control" the BLP14 drive can be used with an analog output motion controller. It is suitable for all other high performance speed control requirements.

Setpoint value

In the current control operating mode the reference value for the motor current is preset. The setpoint value is transmitted via analog input, the fieldbus or the Lexium CT commissioning software.

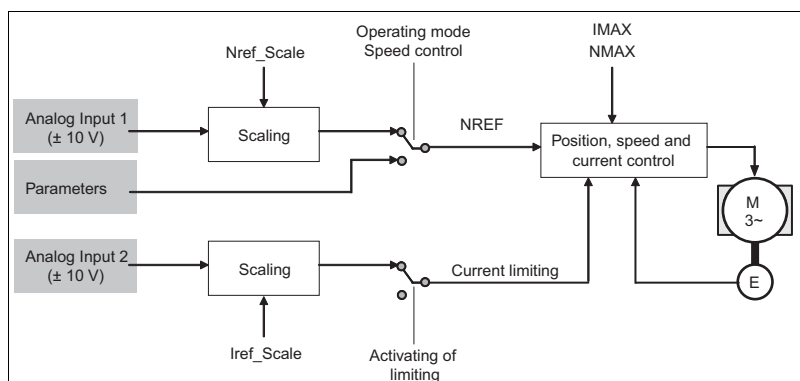

"Current control" operating mode

Possible applications

- Car assembly applications (tool fixing machine)
- Special machines

Speed control

In this mode the BLP14 drive can be used with an analog output motion controller. It is suitable for all other high performance speed control requirements.

Setpoint value

The setpoint value is transmitted via analog input 1, the fieldbus or the commissioning software. Analog input 2 can be used for current or speed limiting.

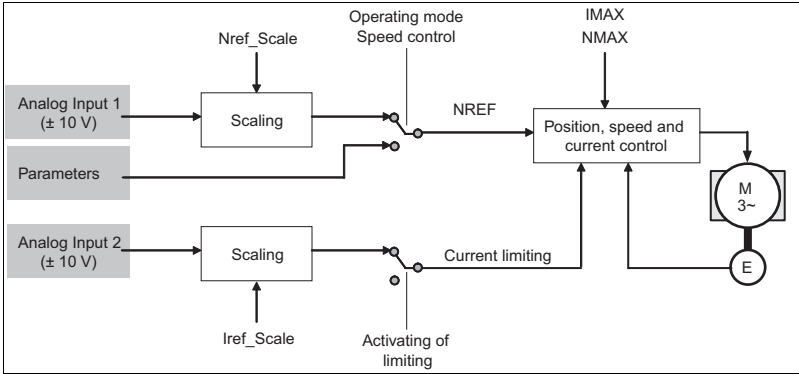

"Speed control" operating mode

Possible applications

- Material handling
- Packaging
- Cutting to length
- Winding and unwinding applications

Point-to-point mode

The "Point-to-point" operating mode, also referred to as PTP (Point To Point), is used to move the axis from a position A to a position B. The movement can be absolute: this consists of expressing position B in relation to a home position (the axis must have previously been referenced), or relative: in this case the movement is performed in relation to the current position of the axis (A). The movement is performed according to acceleration, deceleration and speed parameters.

Setpoint value

The homing parameters are transmitted via the fieldbus or using the Lexium CT commissioning software.

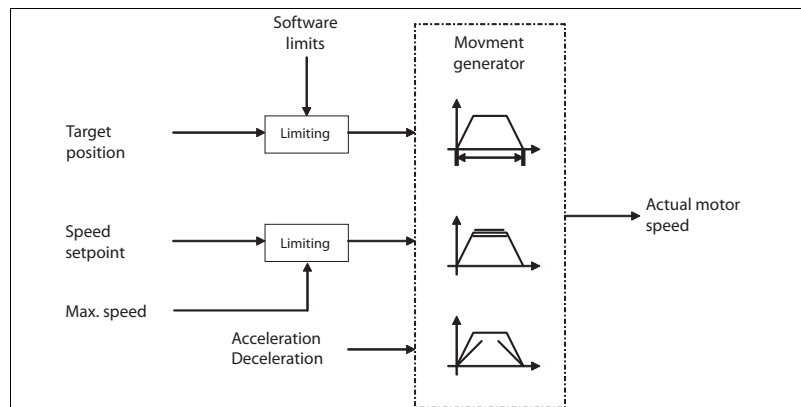

"Point-to-point" operating mode, absolute and relative

Possible applications

A motion controller for coordinated axes or a PLC can manage several axes controlled via fieldbus. This mode is often used in material handling, e. g. automated inspection.

Profile velocity

In the "Profile velocity" operating mode, the speed setpoint is applied according to an acceleration/ deceleration ramp that can be adjusted using parameters. The speed setpoint can be modified during the movement. Current limiting is also possible. The position control that is present in the background allows flexible synchronization of two axes that are in speed control mode, and enables position control mode to be entered on the fly.

Setpoint value

The setpoint value is transmitted via the fieldbus or using the Lexium CT commissioning software.

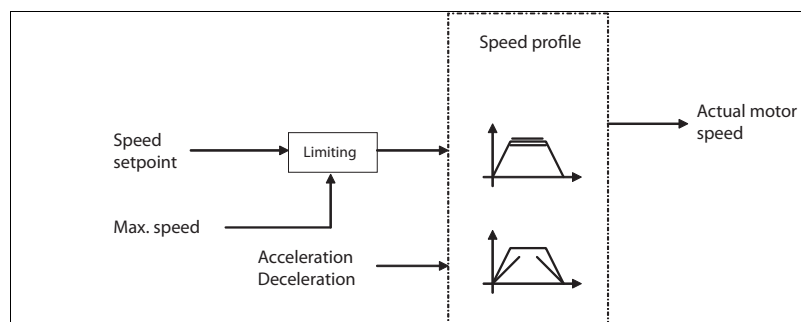

"Profile velocity" operating mode with acceleration/deceleration ramp

Possible applications

This mode is mainly used with infinite axes.
Examples: turntable management, printing, labelling applications

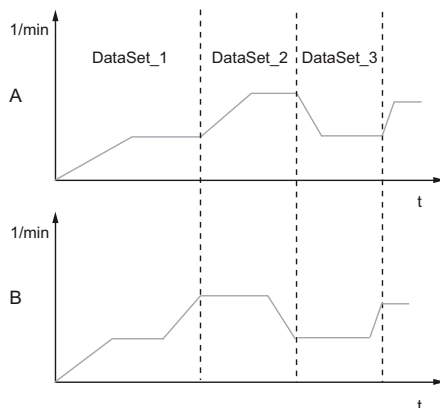
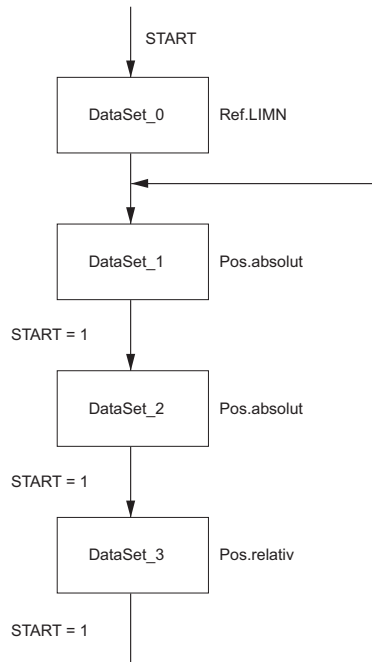

Motion sequence

In the "Motion Sequence" operating mode, up to 16 data sets with movement commands can be activated directly or sequentially with a PC, fieldbus or digital inputs. The movement commands can include reference movements or positioning commands. This way, a motion sequence can be saved in the drive system and controlled via a master PLC.

The Lexium CT commissioning software or the fieldbus is used to enter data sets and parameterise the drive system.

Direct selection of movement commands

The direct selection of movement commands is used if a master controller (e.g. PLC) controls the time coordination of the various data sets. The data set to be processed is selected via signal inputs and then activated by a start signal.

Sequential selection of movement commands

Sequential selection of the movement commands is used for processing simple motion sequences. The time coordination is programmed in the individual data sets via specification of a wait time, a transition condition and the subsequent data set. A transition condition can be, for instance, a rising edge at the START signal input. A motion sequence can also be executed cyclically with or without return to the initial position.

Processing status of a movement command

The processing status of a movement command can be output via the handshake output. In addition, an internal processing status such as "drive system in motion" can be output via an additional signal output.

Selection of the motion profile

Speeds and accelerations are saved in motion profiles. One of the motion profiles can be assigned to every movement command data set.

Blended movement

In the case of sequential selection of movement commands, a blended movement can be specified as a transition condition in the data set. When the target position is reached, the drive accelerates or decelerates to the speed of the subsequent data set.

There are two types of blended movement:

Blended movement A	After reaching the target position, the drive switches to the speed of the subsequent data set.
Blended movement B	When the target position is reached, the drive is to have speed of the subsequent data set.

Monitoring functions

The monitoring functions in the product protect the system and reduce the risks involved in a system malfunction. These monitoring functions are not sufficient for personal protection. The following errors and limit values can be monitored:

Monitoring	Task	Protective function
Blocking error	Error message if the motor shaft remains stopped over a specified period even with maximum current	Functional safety
Data link	Error response in event of connection break	Functional safety and system protection
Limit switch signals	Monitoring of permissible area of travel	System protection
I ² t Limit	Power limitation in event of overloading	Device protection
Short circuit	Monitoring for short circuits between the motor phases	Device protection
Tracking error	Monitoring of variation between motor position and setpoint position	Functional safety
Overvoltage and undervoltage	Monitoring for overvoltage and undervoltage of the power supply	Functional safety and device protection
Overtemperature	Monitoring device for overtemperature	Device protection

Wiring example
Local control mode

The following figure shows an example of wiring with electrical isolation.

- Local control mode in the Jog operating mode
- Inputs and outputs with factory settings in the Jog operating mode
- Motor with hall sensors
- The "Safe Torque Off" (STO) safety function is not used and bridged to 24VDC.

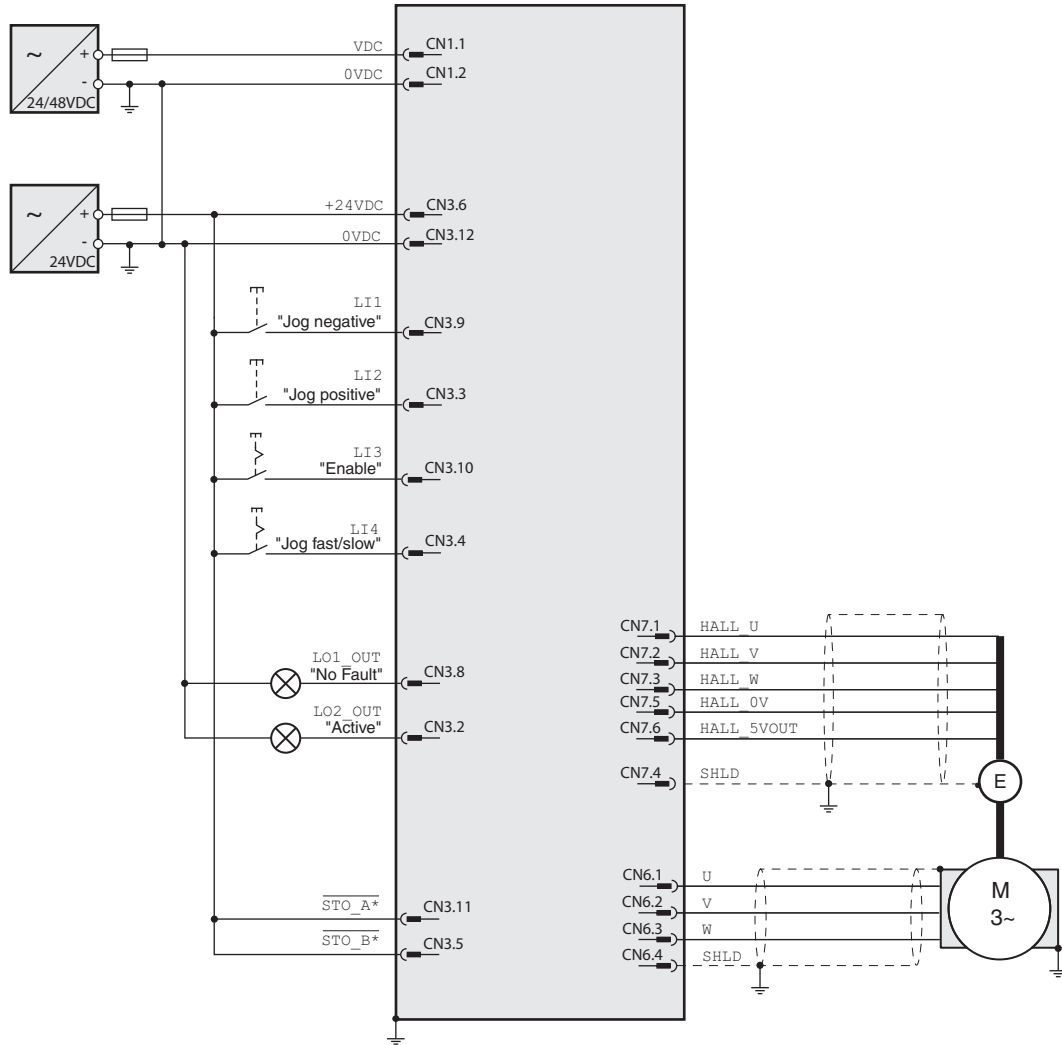

Local control mode in the "Jog" operating mode

The following figure shows an example of wiring with electrical isolation.

- Local control mode in the movement sequence operating mode
- Inputs and outputs with factory settings in the movement sequence operating mode
- Motor with hall sensors
- The "Safe Torque Off" (STO) safety function is not used and bridged to 24VDC.

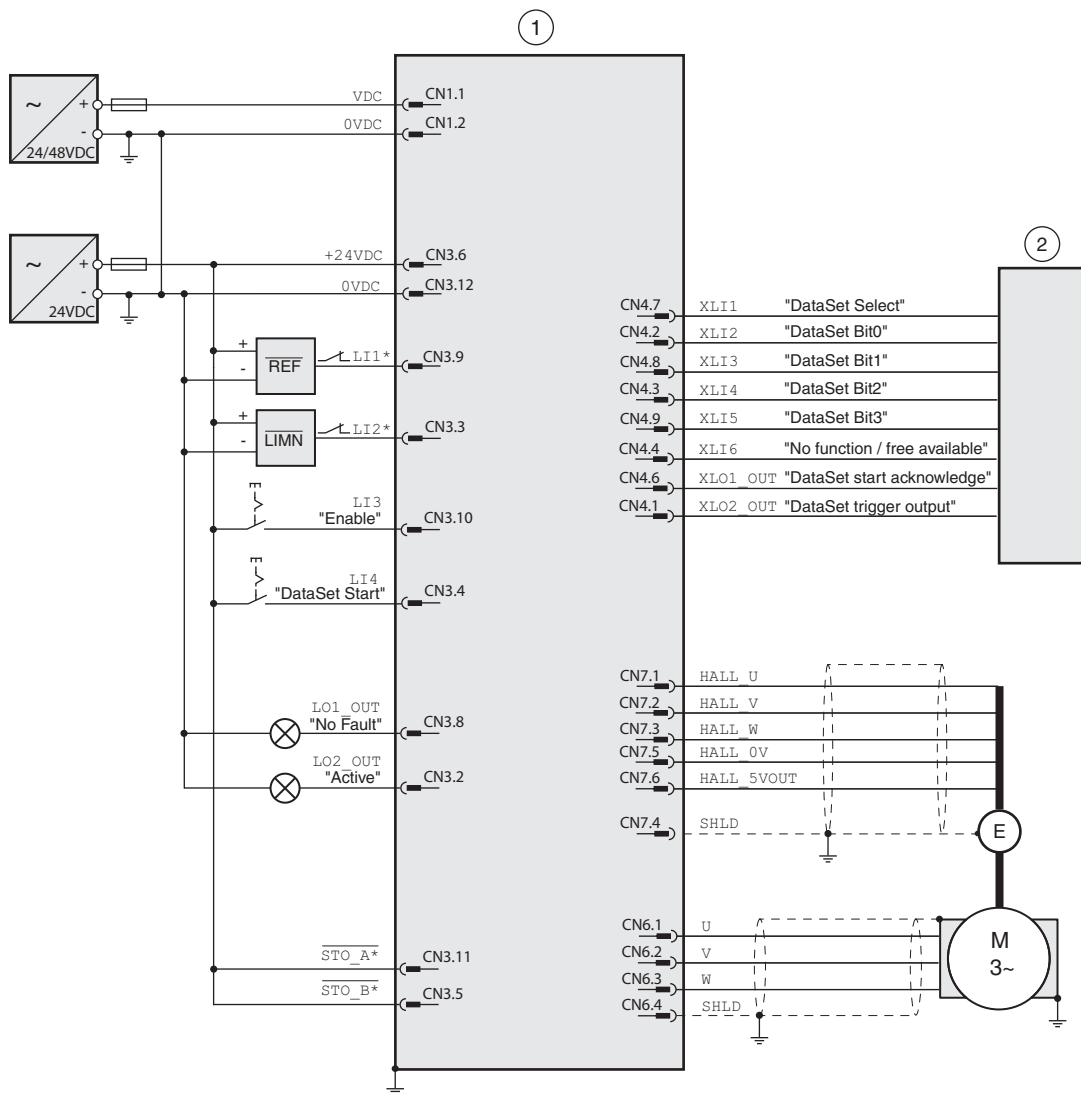

Local control mode in the "Motion sequence" operating mode

- (A) BLP14
- (B) PLC

Field bus control mode

The following figure shows an example of wiring with electrical isolation

- Field bus control mode
- Inputs and outputs with factory settings in the Field bus operating mode.
- "Safe Torque Off" (STO) safety function with EMERGENCY OFF switch without emergency off module
- Motor with hall sensors and incremental encoder
- Braking Resistor Controller UBC60 (accessory)

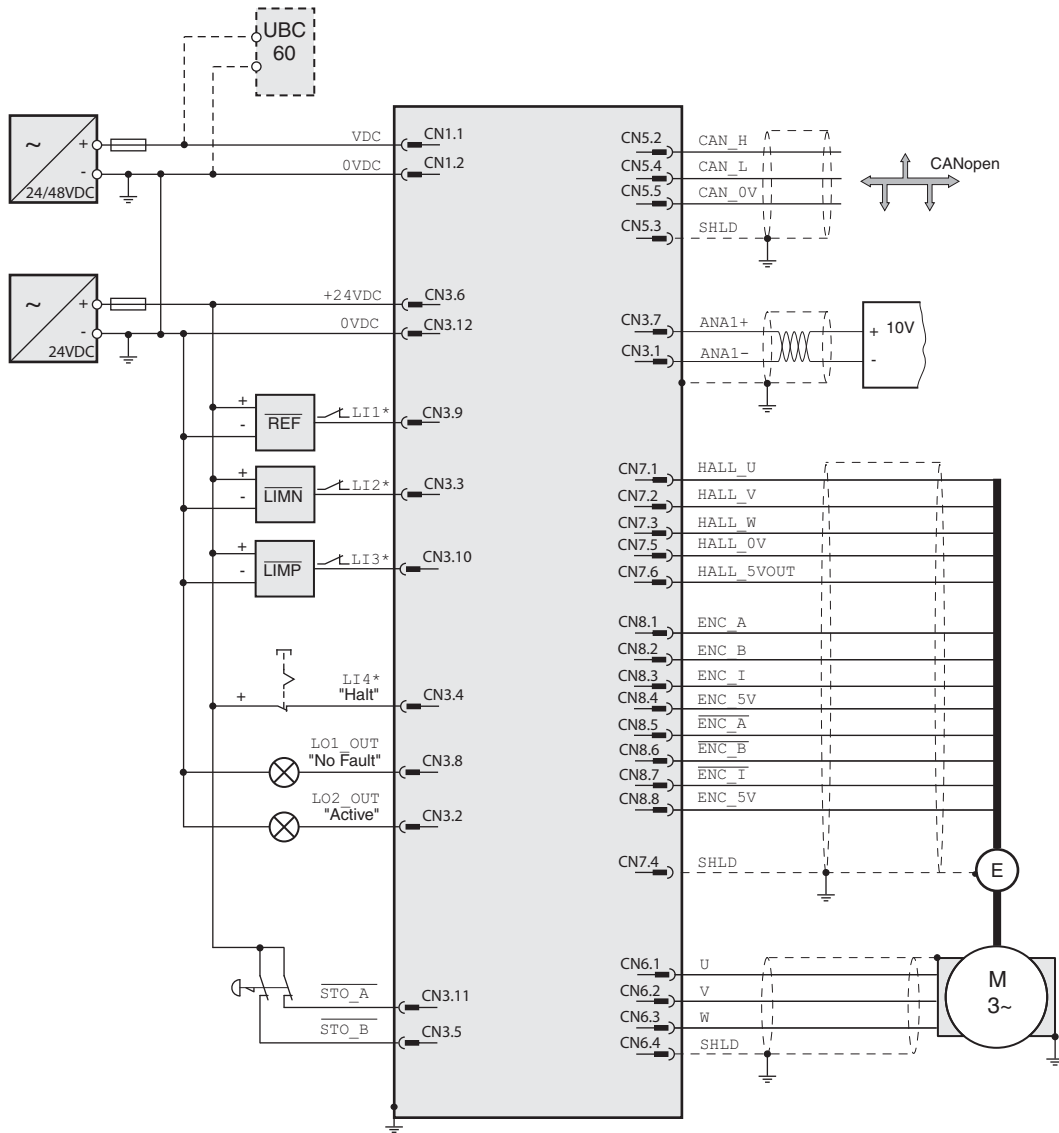

Wiring example in fieldbus control mode

Technical data

Mechanical data

Dimensions (B x H x T)	mm	141.5 x 36 x 86
Weight	kg	0,38
Type of cooling		Free convection

Electrical data

Power data		
Nominal Voltage	V _{DC}	24 ... 48
Limit values	V _{DC}	19.2 ... 60
Residual ripple	%	< 5%
Current consumption	A	7
Current consumption short term	A	14
Input power at 24V _{DC} (short term)	W	150 (300)
Input power at 48V _{DC} (short term)	W	300 (600)
Power loss	W	≤ 7
Internal capacitors	μF	1100
Fuse to be connected in series	A	10
Commissioning interface at CN2		
Transmission rate	kBaud	9.6 / 19.2 / 38.4
Transmission protocol		Modbus RTU
I/O signal interface at CN3 and CN4 (optional)		
Signal input		
Logic 0 (V _{low})	V	-3 ... 5
Logic 1 (V _{high})	V	15 ... 30
Input current (typically at 24V)	mA	3.5
Debounce time	ms	1.25 ... 1.5
Analog inputs		
Differential input voltage range	V _{DC}	-10 ... 10
Zero voltage window	mV	50
Max. input voltage	V _{DC}	± 30
Input resistance	kΩ	≥ 10
Resolution	Bit	14
Sampling time	ms	0.25
Signal outputs		
Voltage range	V	10 ... 30
Max switching current of the output (L01_out)	A	1.5
Max. switching current of the outputs (L02_out, XL01_out, XL02_out)	mA	200
Inductively chargeable	mH	1000
Voltage drop at 50 mA load	V	≤ 1
STO safety function at CN3		
Logic 0 (U _{low})	V	-3 ... 5
Logic 1 (U _{high})	V	15 ... 30
Input current range STO_A (typically at 24V)	mA	≤ 10
Input current range STO_B (typically at 24V)	mA	≤ 3
Debouncing time	ms	1 ... 5
Max. delay until detection of signal differences of STO_A and STO_B ¹⁾	s	< 1
Response time (until shutdown of power amplifier)	ms	< 50
Permitted test pulse width of upstream devices	ms	< 1
Field bus interface CN5		
Transmission rate	kBaud	50 / 125 / 250 / 500 / 1000
Transmission protocol		CANOpen as per CiA301
Device profile		CANOpen as per CiA402
Motor connection (CN6)		
Max. motor phase current	A _{rms}	16
Continuous output current	A _{rms}	8
Phase count		3
Electrical motor time constant	ms	> 0.8
Switching frequency of power amplifier	kHz	16

¹⁾ Switching procedure must occur simultaneously for both inputs (time lag <1s)

Electrical data

Interface for hall sensors at CN7		
Supply voltage	V _{DC}	5 ±5%
Max. allowable current	mA	200
Short circuit proof		
internal Pull-Up resistor	kΩ	1
maximum commutation frequency	Hz	3000
maximum cable length	m	15
Motor encoder at CN8		
Inputs: ENC_A, ENC_B, ENC_I		
Signal voltage		conforming to RS422
frequency	kHz	≤ 400
	inc/s	≤ 1600000
Outputs: ENC+5V_OUT		
Supply voltage	V _{DC}	5 ±5%
Maximum output current	mA	100
short circuit proof		

Environmental conditions

Operating temperature	°C	0 ... 50
Transport and storage temperature	°C	-25 ... 70
Pollution degree		Step 2
Rel. Luftfeuchtigkeit		as per IEC 60721-3-3 Class 3K3,5% ... 85%, no condensation allowed
Installation height above mean sea level for 100% power	m	<1000
Installation height	m	<2000; with max. ambient temperature 40 °C, without protective film and a radial distance >50 mm
Oscillation and vibration		As per IEC/EN 60068-2-6 1.5 mm (from 3 Hz ... 13 Hz) 10 m/s ² (at 13Hz ... 150Hz)
Shock loading		As per IEC/EN 60068-2-27, 150 m/s ² (over 11 ms)
Degree of protection		IP20

Dimensional drawings

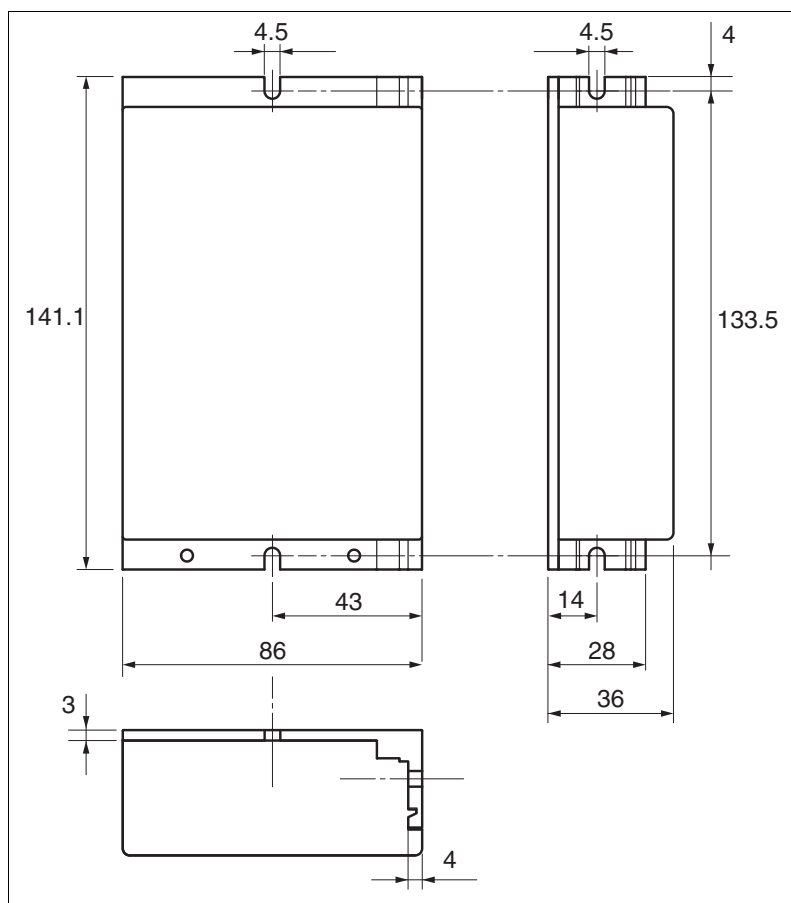

Dimensions of BLP 14A

Mechanical installation

EMC-compliant installation

The BLP brushless DC drive meets the EMC requirements for the second environment as per IEC 61800-3.

An EMC-compliant design is required to maintain the specified limit values. Depending in the case better results can be achieved with the following measures:

- Upstream mains reactors. Information on current harmonics can be obtained on request.
- Upstream external mains filters, particularly to maintain limit values for the first environment (living area, category C2)
- Particularly EMC-compliant design, e.g. in an enclosed control cabinet with 15 dB damping of radiated interference

EMC measures for BLP brushless DC drive

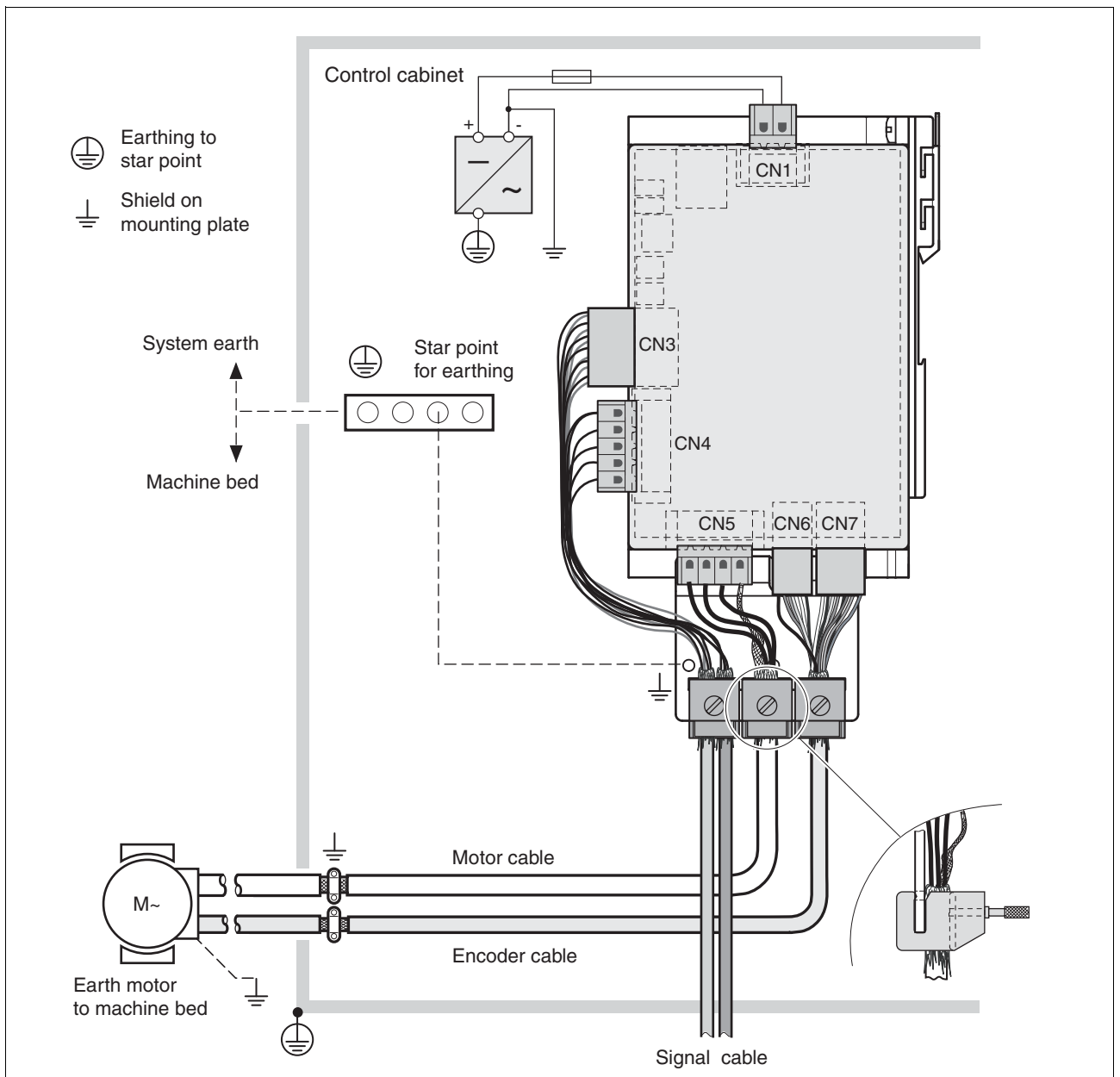

EMC measure

Type code

Example	BLP14	A	D16	B4	00
Product name BLP14 = Drive for EC motors	BLP14	A	D16	B4	00
Interface A = CANopen / analog	BLP14	A	D16	B4	00
Peak current D16 = 16 A _{rms}	BLP14	A	D16	B4	00
Power supply B4 = 24 ... 48 V _{DC}	BLP14	A	D16	B4	00
Other options 00 = Standard 10 = I/O expansion	BLP14	A	D16	B4	00

Functions

Parameter setting

The following functions can be set with the parameter switches of the BLV brushless DC drive:

- Motor phase current
- Closed-loop / open-loop operation
- Internal / external speed default
- Control parameters and speed range
- Speed of rotation or acceleration ramp

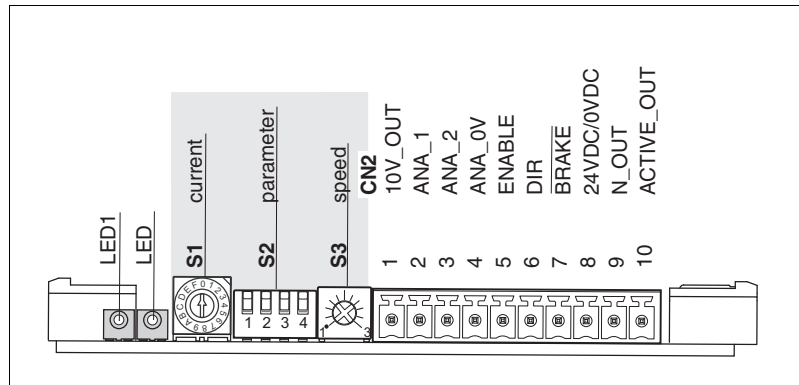

Parameter switches

All parameter settings are queried when switching from `DISABLE` to `ENABLE`.

Setting motor phase current

The motor phase current is set with parameter switch S1. The continuous current is limited to half the peak current to protect the motor. The correct setting can be selected depending on the operating mode and the application. The following values can be set via parameter switch S1:

Switch setting S1	Motor phase current in A
0 (factory setting)	0.1
1	1.3
2	2.7
3	4.0
4	5.3
5	6.7
6	8.0
7	9.3
8	11.0
9	12.3
A	13.7
B	15.0
C	16.3
D	17.7
E	19.0
F	20.3

The maximum motor phase current (and thus the torque) is set via the analogue input `ANA_2` or the 16-step switch S1. The value of `ANA_2` or S1 that is higher is used. This means that the unused setting options must always be set to the lowest value.

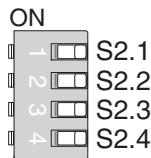

Setting operating mode and default source

S2.1 speed control (closed loop) and speed control (open loop)

In the case of the speed control (closed loop) the speed of rotation depends on the setting of S2.2 either corresponding to the default of the analogue input or the internal potentiometer. The distances of the commutation signals are measured and compensated in accordance with the default.

In the case of the speed control (open loop) the motor behaves like a conventional DC motor. This means that the speed of rotation decreases as the load increases.

Switch setting S2.1	Description
OFF (factory setting)	Speed control (closed Loop)
ON	Speed control (open loop)

S2.2 setting default source

The default for the open-loop speed control and closed-loop speed control can be set via an external analogue signal ANA_1 or the internal potentiometer.

When the default is via the internal potentiometer a fixed acceleration ramp is set. When the default is via the ANA_1 input the acceleration ramp can be adjusted from very slow to highly dynamic via the potentiometer S3.

Switch setting S2.2	Description
OFF (factory setting)	Speed default by analogue signal ANA_1
ON	Speed default by potentiometer S3

S2.3 setting speed control depending on the external load

With speed control (closed loop) the control can be set via the parameter switch S2.3 depending on the external load.

Switch setting S2.3	Description
OFF (factory setting)	Speed control with moment of inertia of load ≤ rotor inertia
ON	Speed control with moment of inertia of load > rotor inertia

S2.4 setting speed range with speed control

With speed control (closed loop) the speed range can be set via the parameter switch S2.4.

Switch setting S2.4	pole pairs	Speed range in 1/min
OFF (factory setting)	2	0 ... 6000
	3	0 ... 4000
	4	0 ... 3000
	6	0 ... 2000
ON	2	0 ... 12000
	3	0 ... 8000
	4	0 ... 6000
	6	0 ... 4000

Setting speed of rotation or acceleration ramp

The speed of rotation or acceleration ramp is set by the potentiometer S3.

If switch S2.2 is set to ON, the speed of rotation is set.

If switch S2.2 is set to OFF, the acceleration ramp is set.

Speed control operating mode

In the speed control (closed loop) operating mode the reference value of the motor speed of rotation is set via the analogue input ANA_1 or the internal potentiometer S3. The maximum current can be limited via the analogue input ANA_2 or the parameter switch S1.

The following overview shows the effectivity of the parameters which can be set for this operating mode.

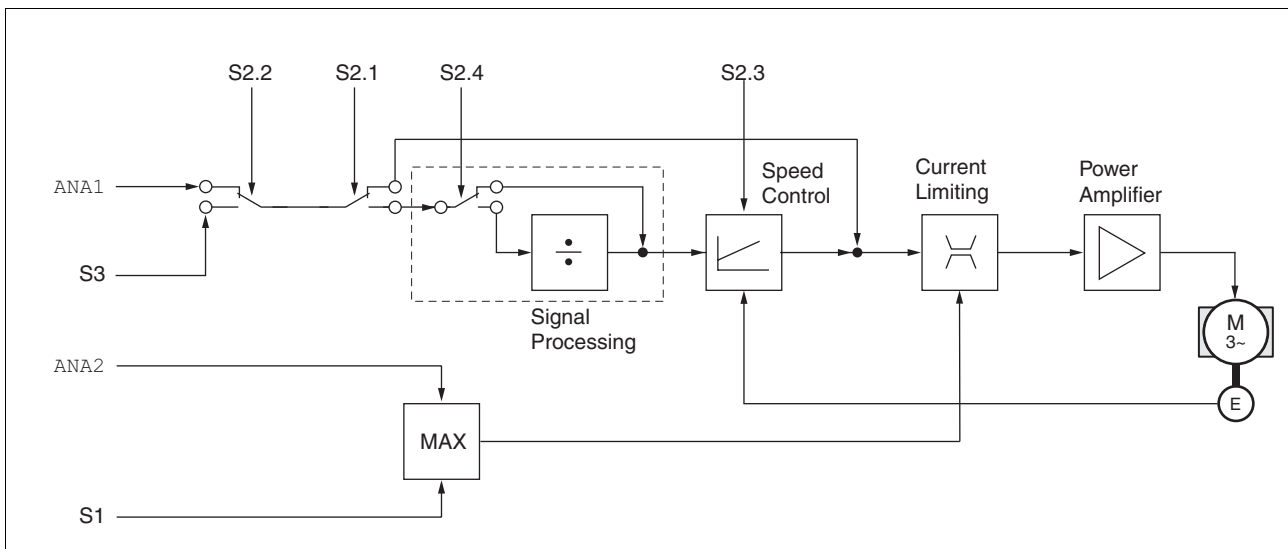

Speed control operating mode, effect of adjustable parameters

Speed control (open loop) operating mode

In the speed control (open loop) operating mode the reference value of the motor speed of rotation is set via the analogue input ANA_1 or the internal potentiometer. The maximum peak current of the motor (and thus the torque) is set via the analogue input ANA_2 or the parameter switch S1. The value of ANA_2 or S1 that is higher is used. This means that the unused setting option must always be set to the lowest value.

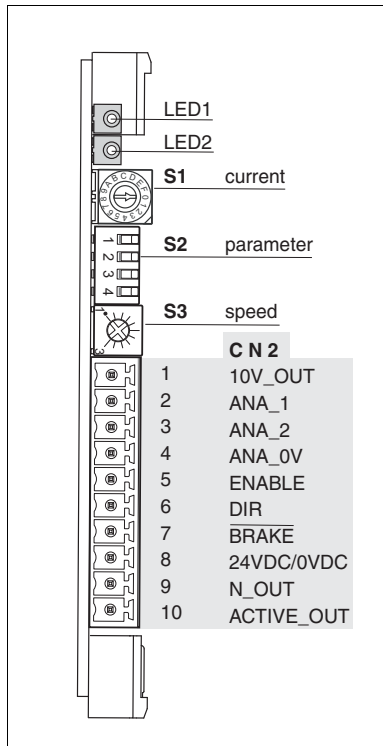

Signal inputs

ENABLE signal input

The **ENABLE** input releases the power amplifier to actuate the motor. Error messages are reset from inactive to active by a switch.

Signal value		BLV14H••	BLV14L••	Description
inactive	V _{DC}	≤ 5	open / 5	Deactivate power amplifier
active	V _{DC}	24	0VDC	Activate power amplifier
Switch from inactive to active		rising edge	Switch from open to 0 VDC	Reset error message

If there is no breakdown, **ACTIVE_OUT** indicates readiness after release of the power amplifier (**ENABLE**) (green LED1 on steady).

When the **ENABLE** signal is removed the power amplifier is blocked immediately, the motor runs down without current.

DIR signal input

The direction of rotation is controlled by the **DIR** signal.

Signal value		BLV14H••	BLV14L••	Description
inactive	V _{DC}	≤ 5	open / 5	Clockwise rotation.
active	V _{DC}	24	0VDC	Counterclockwise rotation.

BRAKE signal input

A motor braking procedure can be triggered via the **BRAKE** input. The input must be activated for normal operation mode.

Signal value		BLV14H••	BLV14L••	Description
inactive	V _{DC}	≤ 5	open / 5	A braking sequence is triggered.
active	V _{DC}	24	0VDC	Normal operating mode.

Signal outputs

ACTIVE_OUT signal output

The **ACTIVE_OUT** signal output shows the operating readiness of the drive system. In the BLV14H• model the output requires the 24VDC signal power supply at CN3 PIN8. This must not be bridged with VDC (danger from feedback).

Signal value		BLV14H••	BLV14L••	Description
inactive	V _{DC}	0VDC	open	Power amplifier switched off.
active	V _{DC}	24VDC	0VDC	Power amplifier activated.

N_OUT signal output (speed signal)

The **N_OUT** signal output initiates a change of edge at every commutation. In the case of motors with, for example, 4 pole pairs 24 changes of edge per revolution are output. In the BLV14H• model the output requires the 24 VDC signal power supply. This must not be bridged with VDC (danger from feedback).

In the dependence on the number of pole pairs of the motor the following number of commutations or signal changes of edge per revolution is derived:

Number of pole pairs	Signal changes of edge / revolution
2	12
3	18
4	24
6	36

Status display via LED

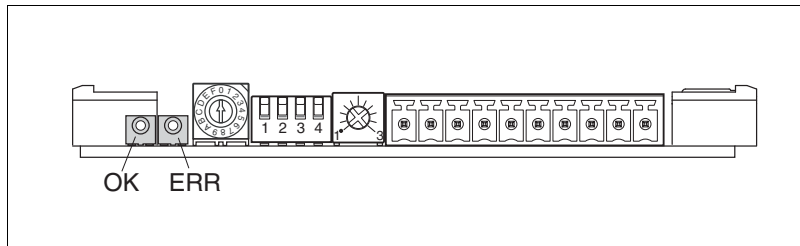

Status display via LED

The two LEDs display the current operating status.

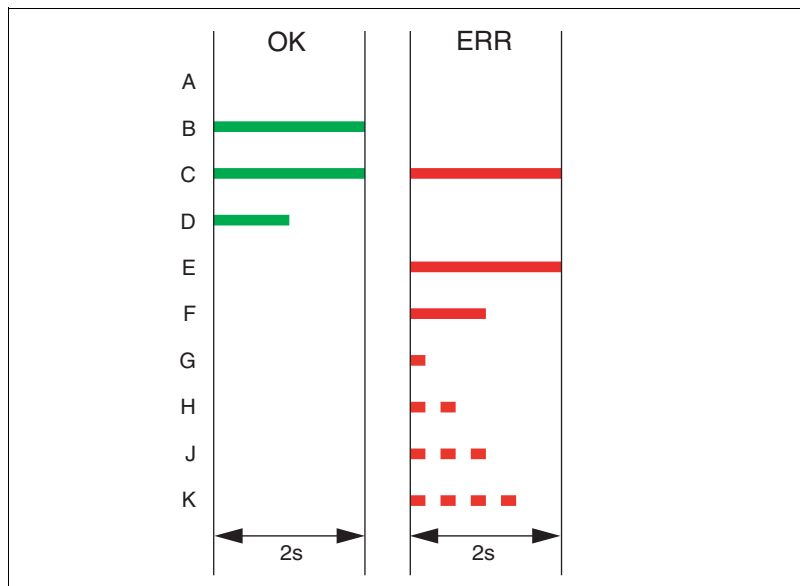

Flash code of LED1 and LED2

- (A) No power supply.
- (B) Power amplifier is activated.
- (C) Holding brake set.
- (D) Power amplifier is deactivated.
- (E) System error.
- (F) Power amplifier overtemperature.
- (G) Overvoltage, including with feedback.
- (H) Undervoltage.
- (J) Commutation error.
- (K) Short circuit between two motor phases.

Wiring examples

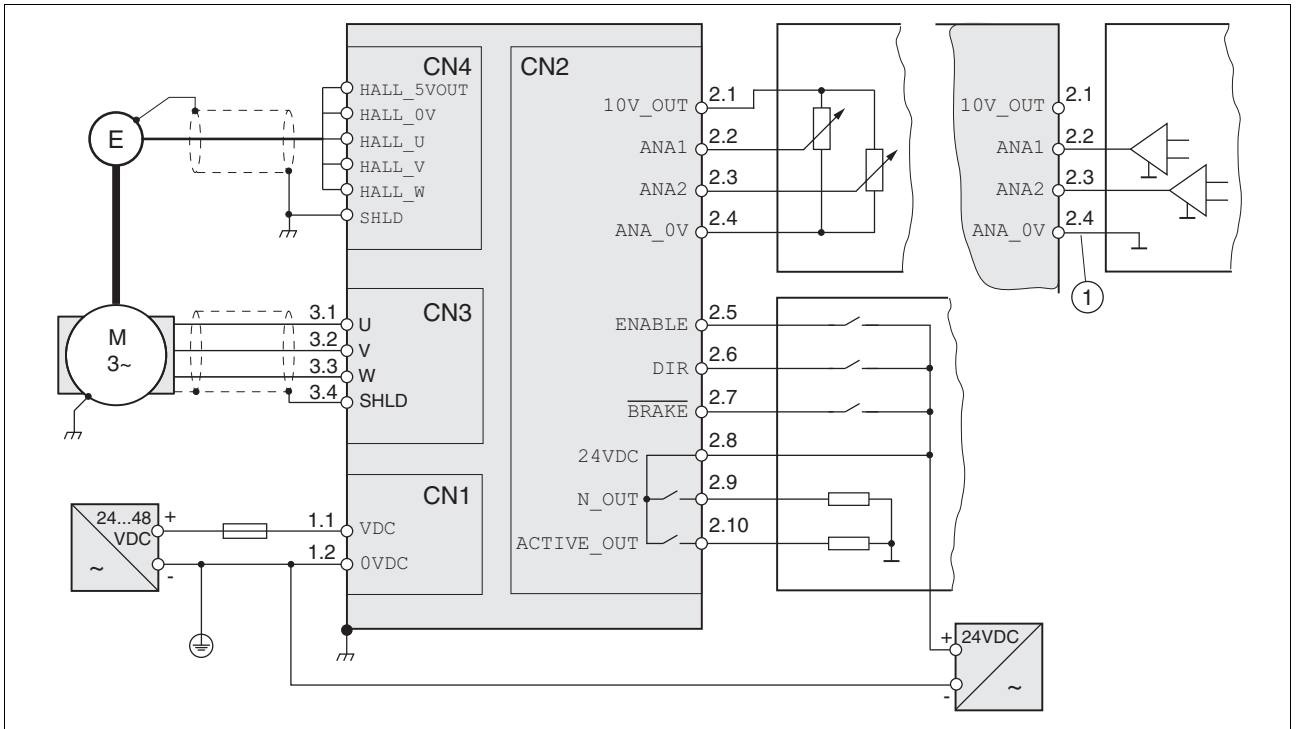

Wiring example of BLV14H

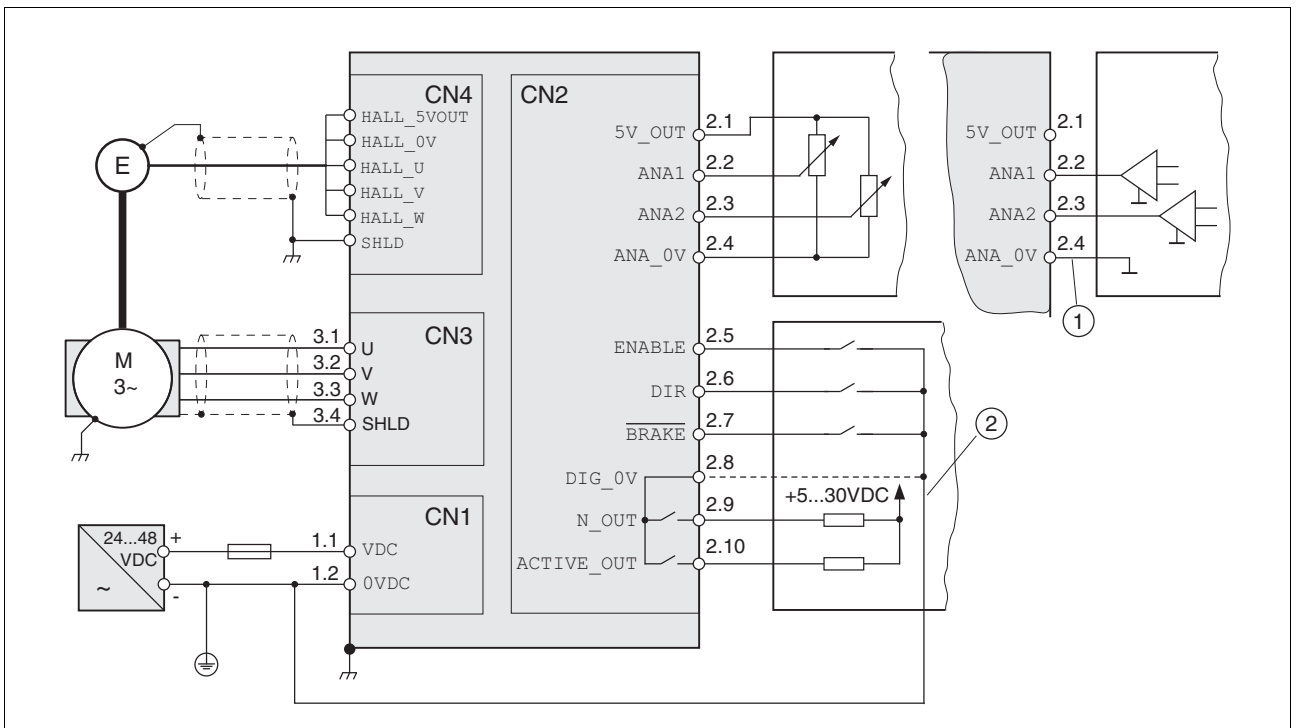

Wiring example of BLV14L

- (1) When all electrical connections are disconnected, ANA_0V can be connected.
- (2) When the electrical connection is disconnected with 0VDC, the dashed connection of 2.8 must be connected.

Technical data

Mechanical data

Dimensions (H x W x D)	mm	23.5 x 117 x 74.5
Weight	kg	0.25
Type of cooling		Free convection

Electrical data

Power data			
Nominal voltage	V _{DC}	24 ... 48	
Input voltage	V _{DC}	-15% / +20% ¹⁾	
Residual ripple		< 5%	
Current consumption	A	6.5	
Nominal power (power output)	W	150 / 300 ²⁾	
Power loss	W	≤ 7	
Capacity value	μF	1100	
Signal interfaces		BLV14H**	BLV14L**
Analogue inputs			
Measuring range	V _{DC}	0 ... 10	0 ... 5
Max. input voltage	V _{DC}	30	10
Input resistance	kΩ	≥10	≥10
Resolution	Bit	10	10
Digital inputs			
Active	V _{DC}	15 ... 30	0 VDC / < 0.8
Inactive	V _{DC}	≤ 5	open / > 4 ... 6
Input current	mA	≤ 7	-
Debounce time	ms	1 ... 2	1 ... 2
Output for potentiometer			
Voltage	V _{DC}	10	5
Max. allowable current	mA	≤ 20	≤ 10
Potentiometer resistance	kΩ	1	1
Digital outputs			
Max. switching voltage	V _{DC}	≤ 30	≤ 30
Max. switching current	mA	≤ 50	≤ 50
Voltage drop at 50 mA load	V _{DC}	≤ 0.5	≤ 0.5
Short-circuit-resistant and overload-proof		yes	yes
Nominal voltage 24V	V _{DC}	24 ²⁾	0 VDC / < 0.8
N_OUT output (speed signal)			
Number of pole pairs		Signal changes of edge / revolution	
2		12	
3		18	
4		24	
6		36	

¹⁾ The levels correspond to EN 61131-2 Type 1

²⁾ For power supply of ACTIVE_OUT and N_OUT outputs. Must not be bridged with VDC power supply, otherwise danger of feedback.

Ambient conditions

Ambient temperature ¹⁾	°C	0 ... +50
Transport and storage temperature	°C	-25 ... +70
Pollution degree		Step 2
Rel. humidity		as per IEC 60721-3-3, Class 3K3, 5 ... 85%, non-condensing
Installation height above mean sea level for 100% power	m	< 1000
Installation height	m	< 2000; with max. ambient temperature 40 °C, without protective film and a radial distance >50 mm
Oscillation and vibration		as per IEC/EN 60068-2-6 3 ... 13 Hz: 1.5 mm peak 13 ... 150 Hz: 1g
Shock loading		as per IEC/EN 60068-2-27 15 g for 11 ms
Degree of protection		IP20 IP40 restricted: from above only, without distance to protective cover

¹⁾ No icing

Dimensional drawings

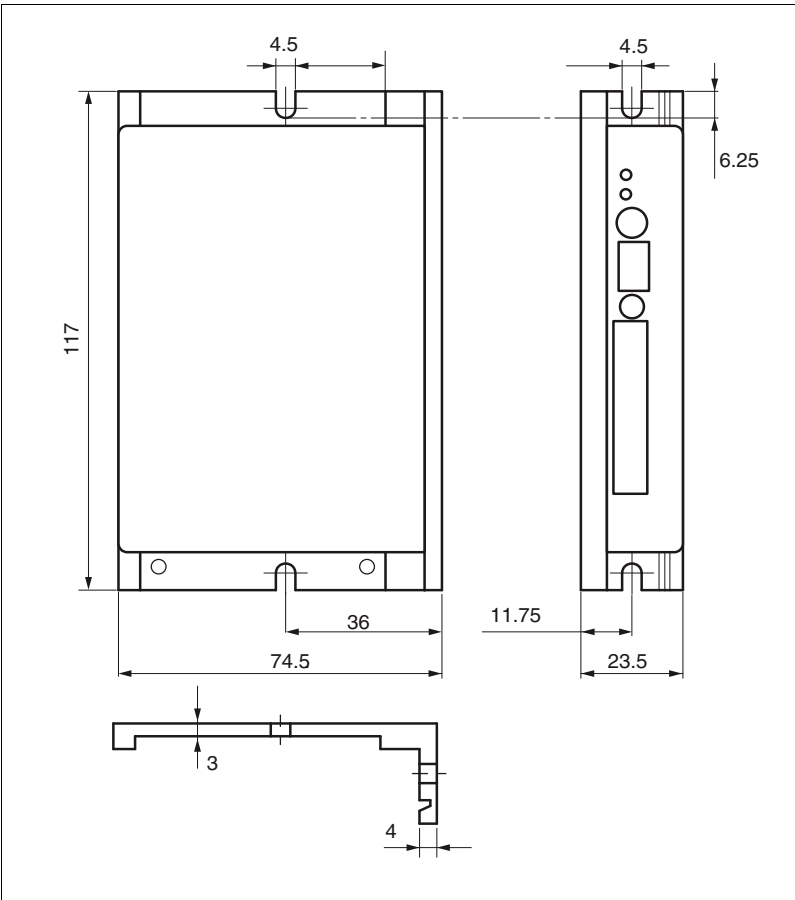

Dimensions of BLV14•

Mounting and installation

EMC-compliant installation

The BLV brushless DC drive meets the EMC requirements for the second environment as per IEC 61800-3.

An EMC-compliant design is required to maintain the specified limit values. Depending in the case better results can be achieved with the following measures:

- Upstream mains reactors. Information on current harmonics can be obtained on request.
- Upstream external mains filters, particularly to maintain limit values for the first environment (living area, category C2)
- Particularly EMC-compliant design, e.g. in an enclosed control cabinet with 15 dB damping of radiated interference

EMC measures for BLV brushless DC drive

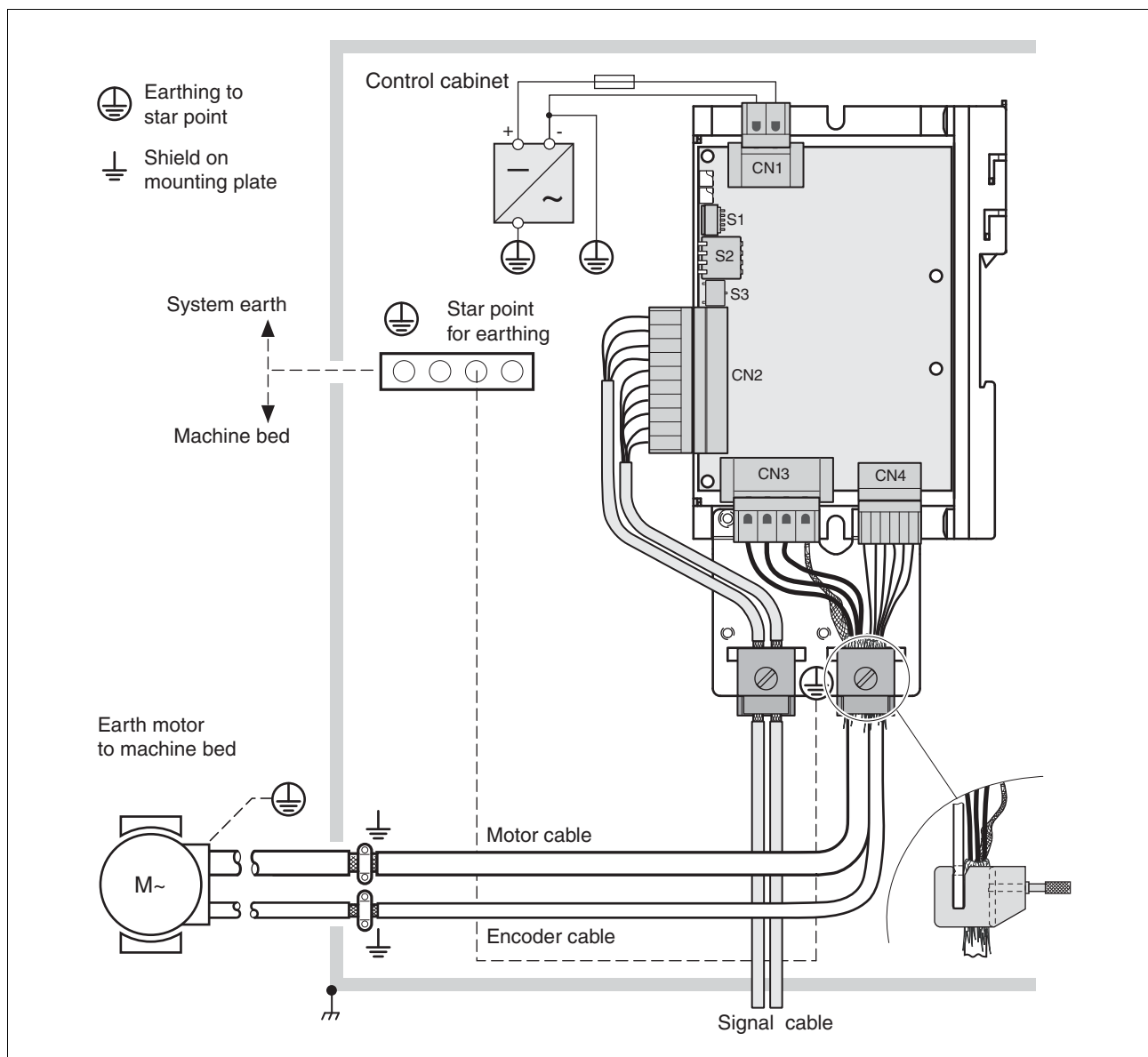

EMC measure

Type code					
BLV14 brushless DC drive					
Example	BLV14	H	D16	B4	00
Product name BLV14 = Power amplifier for brushless DC motors	BLV14	H	D16	B4	00
Interface H = analogue inputs 0 ... 10 V _{DC} ; digital signals 24 V _{DC} L = analogue inputs 0 ... 5 V _{DC} ; digital signals 5 V _{DC}	BLV14	H	D16	B4	00
Peak current D16 = max. 16 A _{eff}	BLV14	H	D16	B4	00
Power supply B 4= 24 ... 48 V _{DC}	BLV14	H	D16	B4	00
Options 00 = Standard	BLV14	H	D16	B4	00

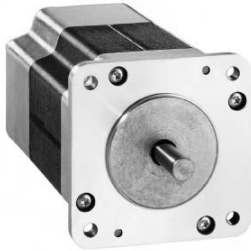

Product description

The motors of the Schneider Electric Motion BDM series are brushless DC motors that are designed as electronically commutated 3-phase synchronous motors. Because of the mechanical design of the brushless DC motor they have a low rotor inertia and very good dynamic characteristics. The use of high-energy magnetic materials means high output power with small sizes. The motors are available with a distinct or low detent torque when not under power.

In specific cases an additional holding brake is unnecessary in the version with high detent torque. The motor version with low detent torque is noted for increased running smoothness.

The motors can be fitted with various types of gearboxgearboxes such as spur wheel or planetary gear depending on the torque and service life requirements. The brushless DC motors are fitted with Hall sensors as standard. For higher positioning resolution, the BDM7● motors can be equipped with an encoder.

Special features

- Motor types with high detent torque that makes a holding brake unnecessary
- Motor types with low holding torque for smooth running
- High torque in relationship to size
- Constant torque over complete speed range

Application possibilities

In industrial applications the brushless DC motors are noted for their high power density with small dimensions and high efficiency. Examples of applications are conveyor drives, pump drives, applications in the textile industry and format changes.

The BDM 4• motors with the flange dimension of 42 mm are particularly useful in device technology for new functions, such as in coffee machines and centrifuges.

Product quotation

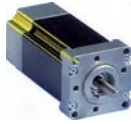
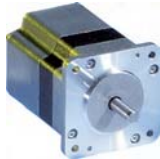
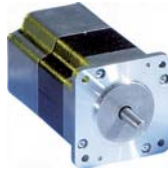
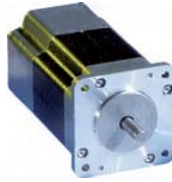
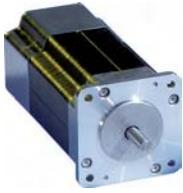
		BDM 43		BDM 45					
									
BDM...		433	434	453	454				
Flange dimension	mm	42							
Shaft diameter	mm	6							
DC bus voltage U_{DC}	V	24 / 48							
Nominal power P_N	W	57	60	100	100				
Nominal speed n_N	1/min	4000	4400	4500	4225				
Nominal torque M_N	Nm	0.14	0.13	0.22	0.22				
Continuous holding torque M_{d0}	Nm	0.12	0.14	0.21	0.23				
Max. torque M_{max}	Nm	0.3	0.4	0.6	0.8				
		BDM 72		BDM 74		BDM 75		BDM 77	
									
BDM...		722	724	742	744	752	754	772	774
Flange dimension	mm	66							
Shaft diameter	mm	8							
DC bus voltage U_{DC}	V	24 / 48 / 325				48 / 60 / 325			
Nominal power P_N	W	120	120 ... 130	180 ... 190	160 ... 200	250	310 ... 320	350 ... 370	340 ... 370
Nominal speed n_N	1/min	4800 ... 4850	4300 ... 4350	4500 ... 4750	4250 ... 4400	5000	4350 ... 4500	5000 ... 5300	4100 ... 4450
Nominal torque M_N	Nm	0.24	0.28	0.38	0.37 ... 0.44	0.48	0.68	0.67	0.80
Continuous holding torque M_{d0}	Nm	0.31	0.33	0.53	0.58	0.81	0.88	1.08	1.09
Max. torque M_{max}	Nm	0.70	0.70	1.40	1.40	2.10	2.10	2.80	2.80

Motor types

Shaft model	Centring collar	Size (Flange dimension)	Length (stator package)	Number of pole pairs	Options
BDM 4•					
Smooth	∅ 6 mm (without gearbox)	∅ 25 mm	4 (42 mm) 3 (25 mm) 5 (50 mm)	3 4	Planetary gear PM42
BDM 7•					
Smooth shaft without gearbox Gearbox with parallel key	∅ 8 mm (without gearbox)	∅ 40 mm	7 (66 mm) 2 (18 mm) 4 (36 mm) 5 (54 mm) 7 (72 mm)	2 4	Planetary gear PM62 Spur wheel gear ¹⁾ Encoder Holding brake ¹⁾

¹⁾ Spur wheel gear cannot be combined with holding brake

Gearbox

Gearbox type	Shaft model	Gear stages	Gear ratio
BDM 4•			
Planetary gear PM42	Parallel key ∅ 8 mm	1 / 2 / 3	7 / 25 / 46 / 93 / 169 / 308
BDM 7•			
Planetary gear PM62	Parallel key ∅ 14 mm	1 / 2 / 3	7 / 16 / 25 / 93 / 115 / 308
Spur wheel gear	∅ 10 mm	2 / 3 / 4	7 / 18 / 38 / 54 / 115

BDM 4•

BDM 433

Dimensional drawing

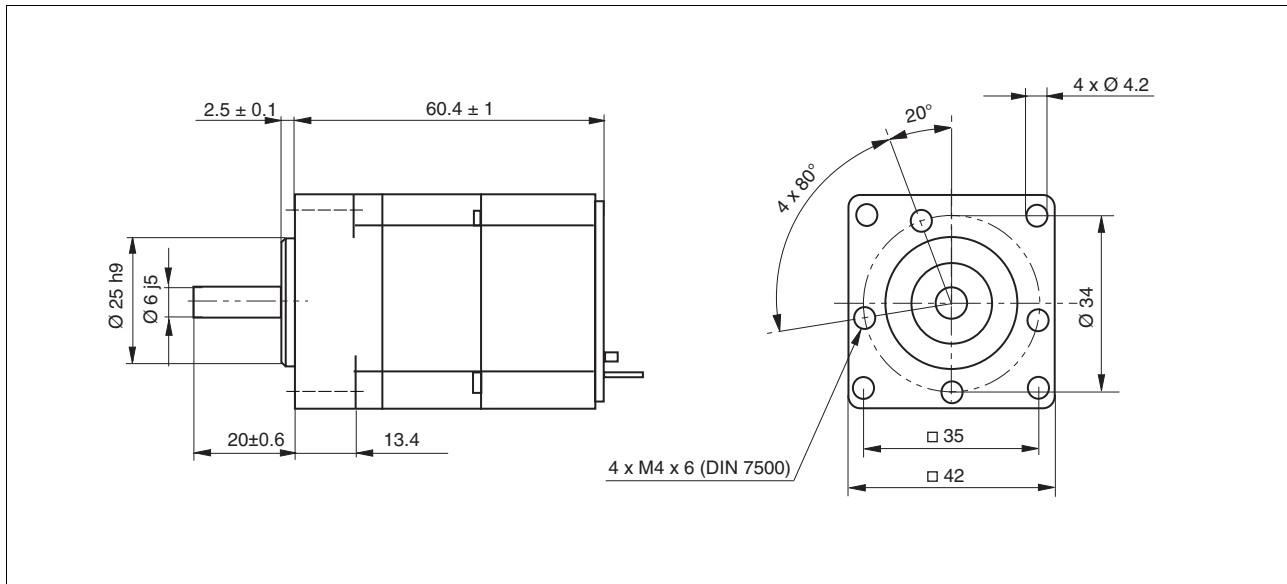

Dimensional drawing BDM 433

Technical data

DC bus voltage U_{DC}	V	24	48
Number of pole pairs p		3	3
Nominal power P_N	W	57	57
Nominal torque M_N	Nm	0.14	0.14
Nominal speed n_N	1/min	4000	4050
Nominal current I_N	A	3.1	1.6
Nominal current \hat{i}_N	A	3.8	2.0
No-load speed n_0	1/min	6500	6600
No-load current I_0	A	0.28	0.15
Continuous holding torque M_{d0}	Nm	0.12	0.12
Continuous holding current I_{d0}	A	3.30	1.70
Max. continuous holding current \hat{i}_{d0}	A	4.05	2.1
Max. torque M_{max}	Nm	0.3	0.3
Max. current I_{max}	A	8.4	4.3
Detent torque M_S	Nm	0.028	0.028
Torque constant (M_{d0}/\hat{i}_{d0}) k_M	Nm/A	0.030	0.059
Generator voltage constant k_{Ett}	mV/(1/min)	2.738	5.367
Terminal resistance R_{tt}	Ω	1.10	3.85
Terminal inductivity L_{tt}	mH	0.86	3.305
Rotor inertia J_R	kg cm	0.062	0.062
Heat resistance (winding/surface) R_{th1}	K/W	0.75	0.75
Ambient temperature	$^{\circ}C$	40	40
Max. permissible radial shaft load F_q	N	50	50
Max. permissible axial shaft load F_a	N	20	20
Mass m	kg	0.35	0.35
Vibration strain as per DIN EN 60068-2-6	m/s^2	20	
Degree of protection as per DIN EN 60592		IP41	IP41
Heat class as per DIN EN 60034-1		130 (B)	130 (B)

Characteristic curves

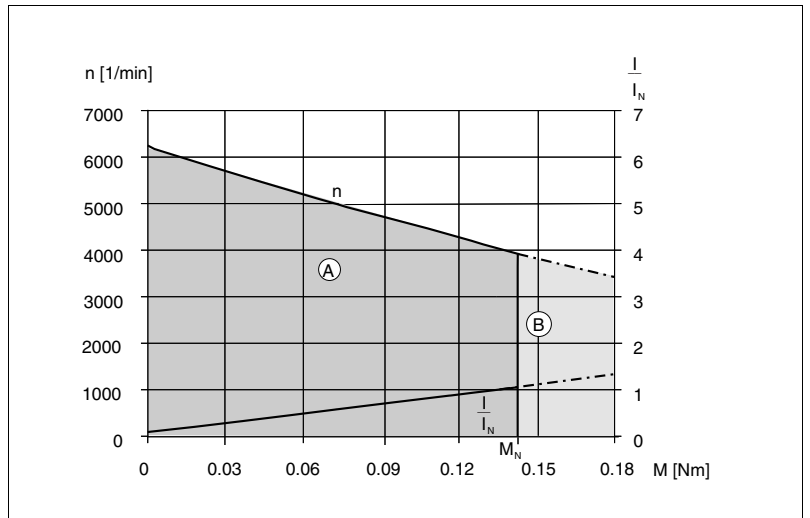

Torque characteristic BDM 433

- (A) S1: continuous operation
- (B) S2 ... S9: short-term operation

Motor connection

Pin	Signal connector
1	Power supply +4 V ... +24 V
2	Power supply GND
3	Hall U
4	Hall V
5	Hall W

Pin	Motor plug
U	Motor
V	Motor
W	Motor

The pull-up resistance is not integrated. The maximum current at the Hall sensors is 30 mA.

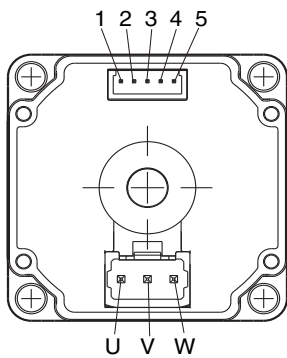

BDM 434

Dimensional drawing

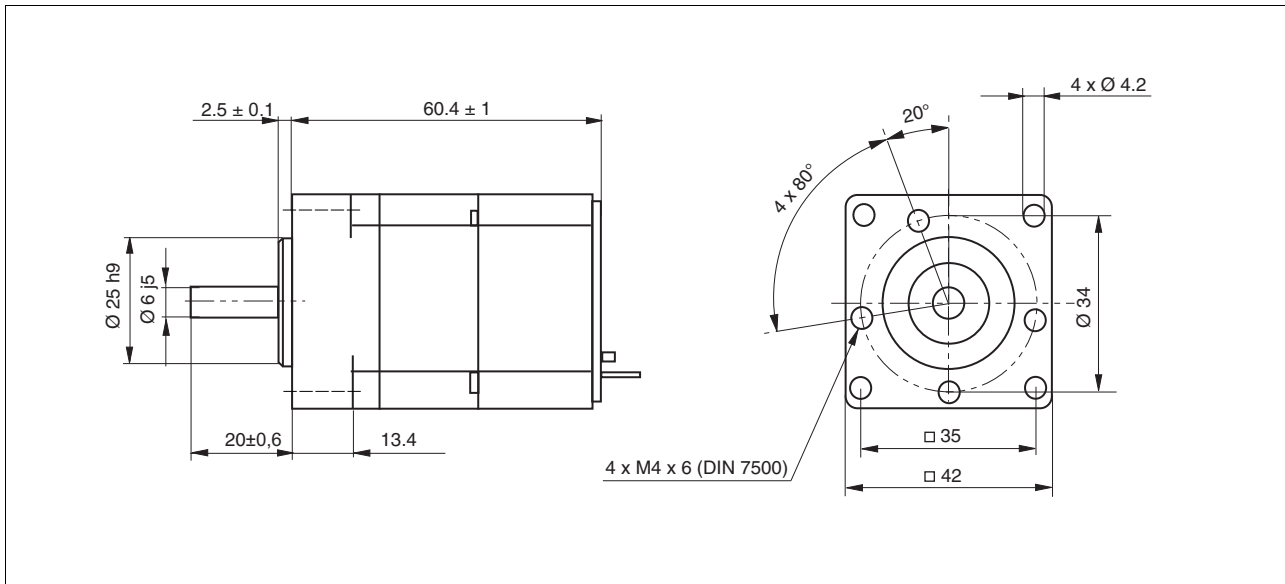

Dimensional drawing BDM 434

Technical data

DC bus voltage U_{DC}	V	24	48
Number of pole pairs p		4	4
Nominal power P_N	W	60	60
Nominal torque M_N	Nm	0.13	0.13
Nominal speed n_N	1/min	4400	4400
Nominal current I_N	A	3.3	1.65
Nominal current \hat{I}_N	A	4.04	2.00
No-load speed n_0	rpm	6800	6950
No-load current I_0	A	0.22	0.12
Continuous holding torque M_{d0}	Nm	0.14	0.14
Continuous holding current I_{d0}	A	4.29	2.3
Max. continuous holding current \hat{I}_{d0}	A	5.25	2.8
Max. torque M_{max}	Nm	0.4	0.4
Max. current I_{max}	A	11.7	6.0
Detent torque M_S	Nm	0.02	0.02
Torque constant (M_{d0}/\hat{I}_{d0}) k_M	Nm/A	0.027	0.051
Generator voltage constant k_{Ett}	mV/(1/min)	2.605	5.086
Terminal resistance R_{tt}	Ω	0.86	2.59
Terminal inductivity L_{tt}	mH	0.67	2.56
Rotor inertia J_R	kg cm ²	0.062	0.062
Heat resistance (winding/surface) R_{th1}	K/W	0.75	0.75
Ambient temperature	°C	40	40
Max. permissible radial shaft load F_q	N	50	50
Max. permissible axial shaft load F_a	N	20	20
Mass m	kg	0.35	0.35
Vibration strain as per DIN EN 60068-2-6	m/s ²	20	
Degree of protection as per DIN EN 60592		IP41	IP41
Heat class as per DIN EN 60034-1		130 (B)	130 (B)

Characteristic curves

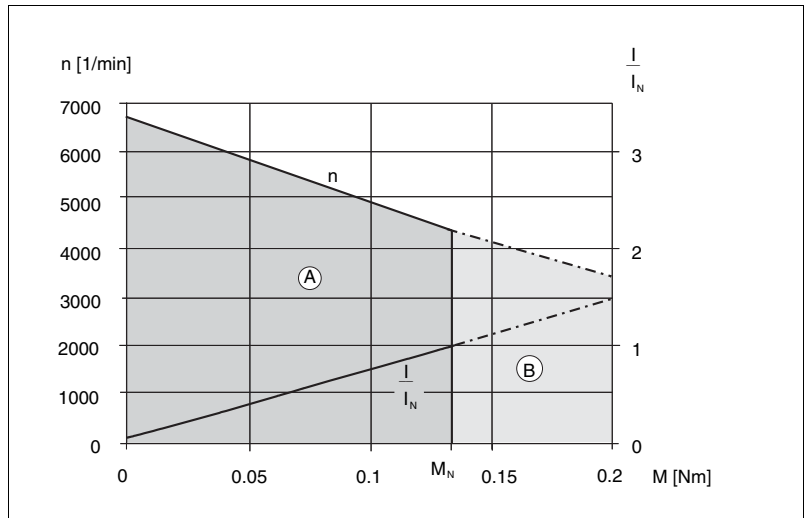

Torque characteristic BDM 434

- (A) S1: continuous operation
- (B) S2 ... S9: short-term operation

Motor connection

Pin	Signal connector
1	Power supply +4 V ... +24 V
2	Power supply GND
3	Hall U
4	Hall V
5	Hall W

Pin	Motor plug
U	Motor
V	Motor
W	Motor

The pull-up resistance is not integrated. The maximum current at the Hall sensors is 30 mA.

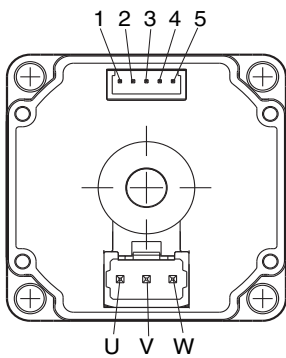

BDM 453

Dimensional drawing

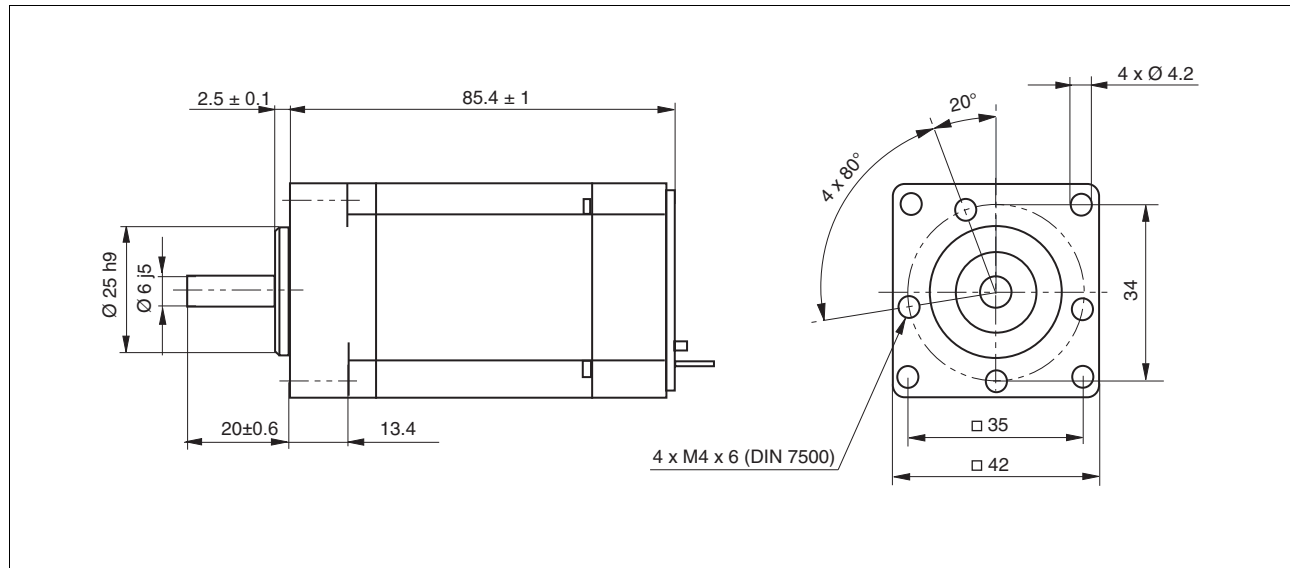

Dimensional drawing BDM 453

Technical data

DC bus voltage U_{DC}	V	24	48
Number of pole pairs p		3	3
Nominal power P_N	W	100	100
Nominal torque M_N	Nm	0.22	0.22
Nominal speed n_N	1/min	4500	4500
Nominal current I_N	A	4.82	2.41
Nominal current \hat{I}_N	A	5.9	3.0
No-load speed n_0	rpm	6250	6000
No-load current I_0	A	0.44	0.20
Continuous holding torque M_{d0}	Nm	0.21	0.21
Continuous holding current I_{d0}	A	5.4	2.7
Max. continuous holding current \hat{I}_{d0}	A	6.61	3.3
Max. torque M_{max}	Nm	0.6	0.6
Max. current I_{max}	A	16.1	7.8
Detent torque M_S	Nm	0.055	0.055
Torque constant (M_{d0}/\hat{I}_{d0}) k_M	Nm/A	0.032	0.063
Generator voltage constant k_{Ett}	mV/(1/min)	2.835	5.887
Terminal resistance R_{tt}	Ω	0.58	2.14
Terminal inductivity L_{tt}	mH	0.435	1.876
Rotor inertia J_R	kg cm ²	0.123	0.123
Heat resistance (winding/surface) R_{th1}	K/W	0.46	0.46
Ambient temperature	°C	40	40
Max. permissible radial shaft load F_q	N	50	50
Max. permissible axial shaft load F_a	N	20	20
Mass m	kg	0.5	0.5
Vibration strain as per DIN EN 60068-2-6	m/s ²	20	
Degree of protection as per DIN EN 60592		IP41	IP41
Heat class as per DIN EN 60034-1		130 (B)	130 (B)

Characteristic curves

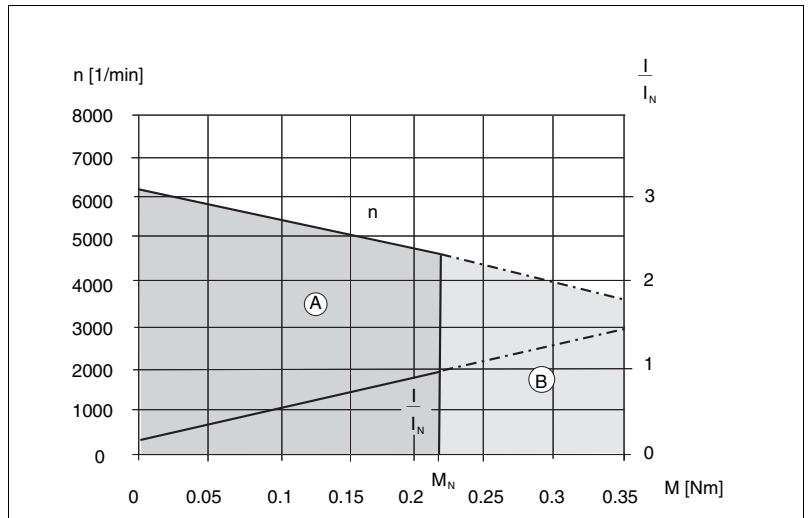

Torque characteristic BDM 453

- (A) S1: continuous operation
- (B) S2 ... S9: short-term operation

Motor connection

Pin	Signal connector
1	Power supply +4 V ... +24 V
2	Power supply GND
3	Hall U
4	Hall V
5	Hall W

Pin	Motor plug
U	Motor
V	Motor
W	Motor

The pull-up resistance is not integrated. The maximum current at the Hall sensors is 30 mA.

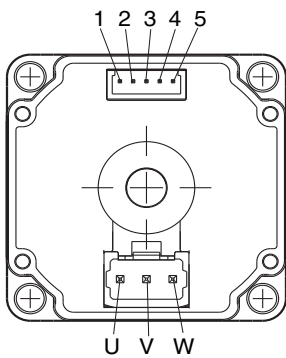

BDM 454

Dimensional drawing

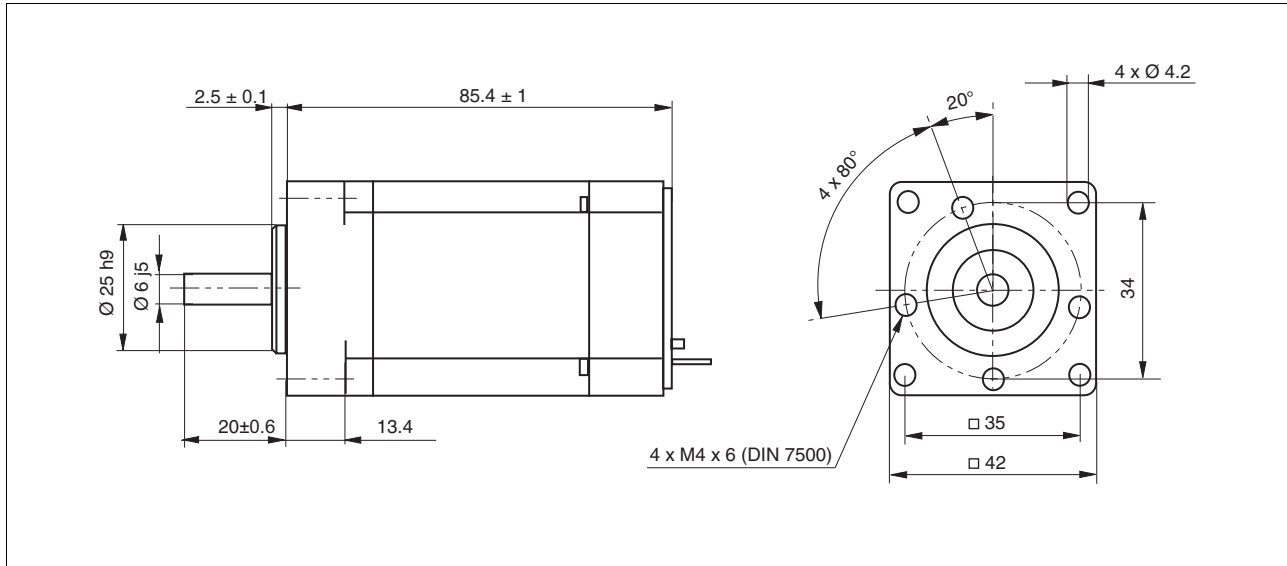

Dimensional drawing BDM 454

Technical data

DC bus voltage U_{DC}	V	24	48
Number of pole pairs p		4	4
Nominal power P_N	W	100	100
Nominal torque M_N	Nm	0.22	0.22
Nominal speed n_N	1/min	4225	4400
Nominal current I_N	A	4.62	1.65
Nominal current \hat{I}_N	A	5.66	2.0
No-load speed n_0	rpm	6350	6650
No-load current I_0	A	0.41	0.22
Continuous holding torque M_{d0}	Nm	0.23	0.23
Continuous holding current I_{d0}	A	6.71	3.2
Max. continuous holding current \hat{I}_{d0}	A	8.21	3.9
Max. torque M_{max}	Nm	0.8	0.8
Max. current I_{max}	A	22.4	11.7
Detent torque M_S	Nm	0.033	0.033
Torque constant (M_{d0}/\hat{I}_{d0}) k_M	Nm/A	0.028	0.058
Generator voltage constant k_{Ett}	mV/(1/min)	2.728	5.209
Terminal resistance R_{tt}	Ω	0.51	1.70
Terminal inductivity L_{tt}	mH	0.344	1.254
Rotor inertia J_R	kg cm ²	0.123	0.123
Heat resistance (winding/surface) R_{th1}	K/W	0.46	0.46
Ambient temperature	°C	40	40
Max. permissible radial shaft load F_q	N	50	50
Max. permissible axial shaft load F_a	N	20	20
Mass m	kg	0.5	0.5
Vibration strain as per DIN EN 60068-2-6	m/s ²	20	
Degree of protection as per DIN EN 60592		IP41	IP41
Heat class as per DIN EN 60034-1		130 (B)	130 (B)

Characteristic curves

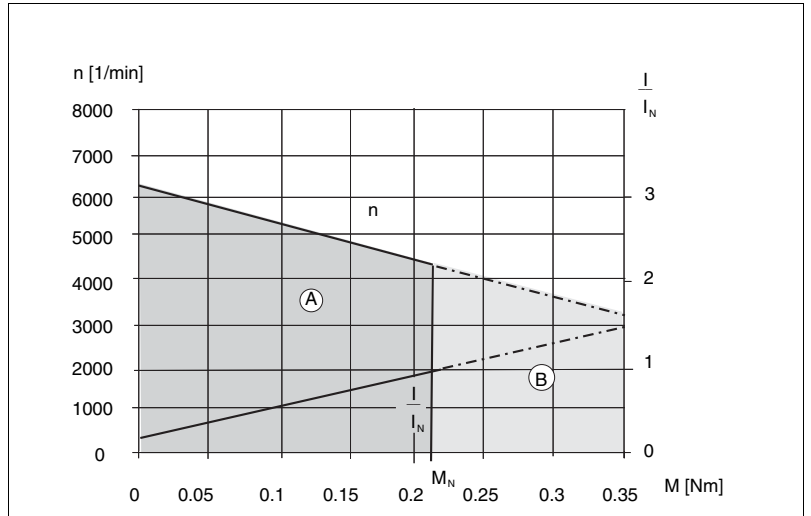

Torque characteristic BDM 454

- (A) S1: continuous operation
- (B) S2 ... S9: short-term operation

Motor connection

Pin	Signal connector
1	Power supply +4 V ... +24 V
2	Power supply GND
3	Hall U
4	Hall V
5	Hall W

Pin	Motor plug
U	Motor
V	Motor
W	Motor

The pull-up resistance is not integrated. The maximum current at the Hall sensors is 30 mA.

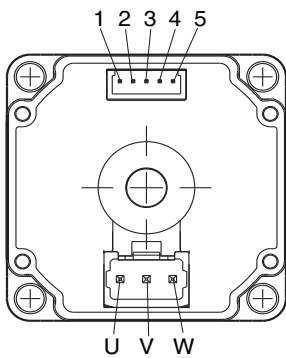

BDM 4• options

BDM 4• with planetary gearbox PM42

Dimensional drawing

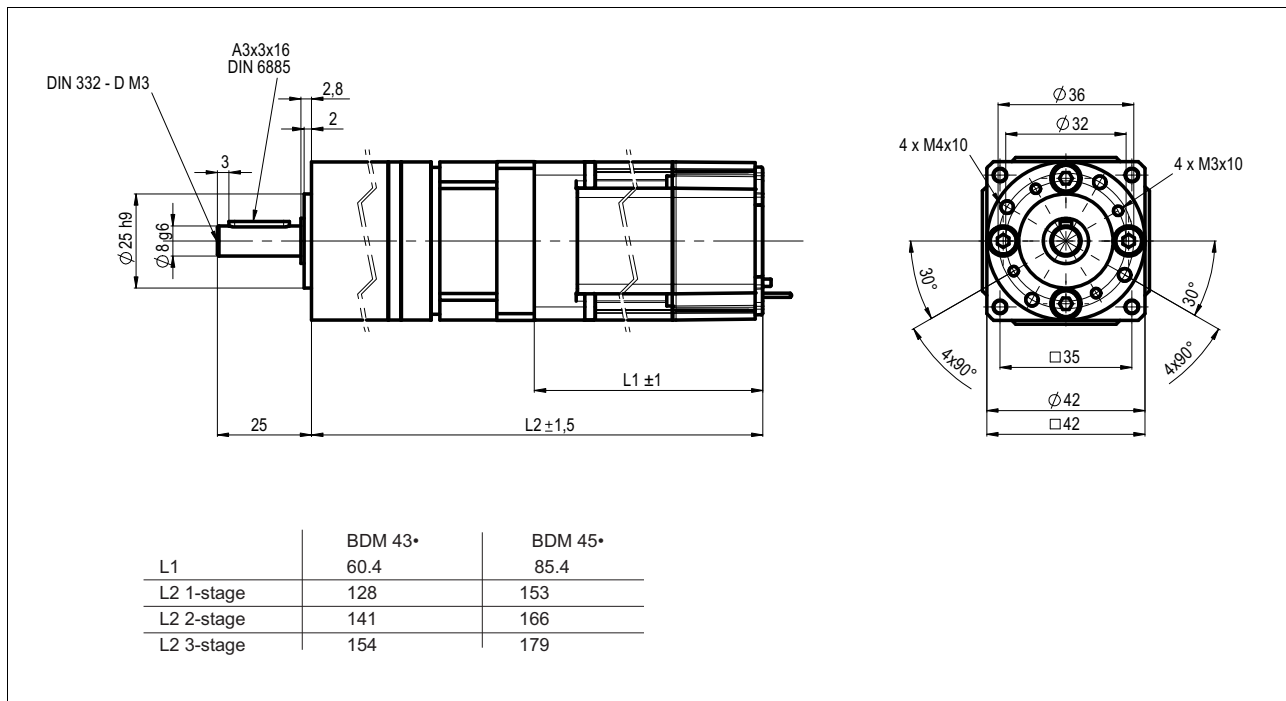

Dimensional drawing BDM 4• with planetary gear PM42

Technical data

		7 (6.75)	25 (25.01)	46 (45.56)	93 (92.7)	169 (168.84)	308 (307.54)
Gear ratio		1	2	2	3	3	3
Gear stages		1	2	2	3	3	3
Max. continuous torque	Nm	3	7.5	7.5	15	15	15
Efficiency	%	80	75	75	70	70	70
Permissible radial force	N	160	230	230	300	300	300
Permissible axial force	N	50	80	80	110	110	110
Housing and teeth		Steel					
Bearings		Ball bearing					
Drive shaft		With parallel key according to DIN 6885					
Seal at shaft exit		Shaft seal ring IP54					
Max. recommended input speed	1/min	3000					
Operating temperature	°C	-30 ... 140					
Expected service life	h	average 2500, depending on load profile					

BDM 4• type code								
Example:	BDM	43	3	2	H	T	A	00
Product family BDM = Brushless DC Motor	BDM	43	3	2	H	T	A	00
Motor size / Motor length 43 = 42 mm / 25 mm 45 = 42 mm / 50 mm	BDM	43	3	2	H	T	A	00
Number of Poles / Holding Torque 3 = 3 poles / High holding torque 4 = 4 poles / Low holding torque	BDM	43	3	2	H	T	A	00
Voltage 2 = 24 V 4 = 48 V	BDM	43	3	2	H	T	A	00
Feedback system H = Hall-Sensor	BDM	43	3	2	H	T	A	00
Electrical connection T = Terminal bar	BDM	43	3	2	H	T	A	00
Holding brake A = without brake	BDM	43	3	2	H	T	A	00
Shaft model / Gearbox type / Gear ratio 00 = without gearbox with planetary gear PM42 M1 = 7:1 (6.75) M2 = 25:1 (25.01) M3 = 46:1 (45.56) M4 = 93:1 (92.7) M5 = 169:1 (168.84) M6 = 308:1 (307.54)	BDM	43	3	2	H	T	A	00

BDM 7•

BDM 722

Dimensional drawing

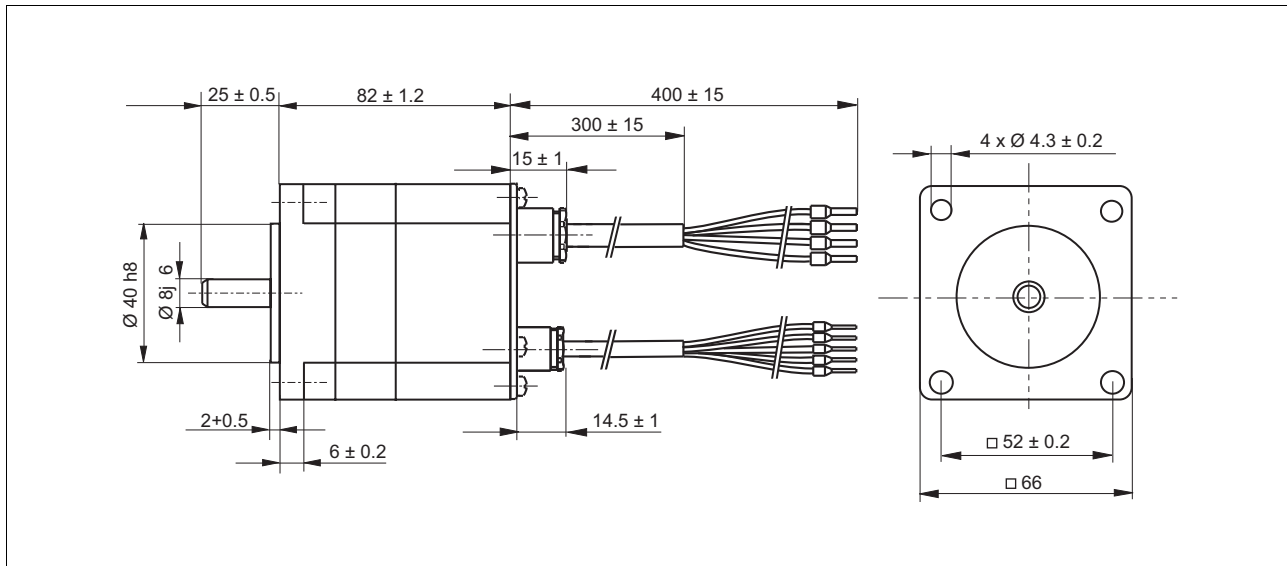

Dimensional drawing BDM 722

Technical data

DC bus voltage U_{DC}	V	24	48
Number of pole pairs p		2	2
Nominal power P_N	W	120	120
Nominal torque M_N	Nm	0.24	0.24
Nominal speed n_N	1/min	4850	4850
Nominal current I_N	A	7.0	3.49
Nominal current \hat{I}_N	A	8.5	4.27
No-load speed n_0	rpm	6400	6400
No-load current I_0	A	0.74	0.37
Continuous holding torque M_{d0}	Nm	0.31	0.31
Continuous holding current I_{d0}	A	8.4	4.36
Max. continuous holding current \hat{I}_{d0}	A	10.3	5.34
Max. torque M_{max}	Nm	0.70	0.70
Max. current I_{max}	A	20.6	10.3
Detent torque M_S	Nm	0.053	0.053
Torque constant (M_{d0}/I_{d0}) k_M	Nm/A	0.030	0.057
Generator voltage constant k_{Ett}	mV/(1/min)	2.602	5.203
Terminal resistance R_{tt}	Ω	0.21	0.70
Terminal inductivity L_{tt}	mH	0.787	3.148
Rotor inertia J_R	kg cm ²	0.170	0.170
Heat resistance (winding/surface) R_{th1}	K/W	1.25	1.25
Ambient temperature	°C	-25 ... 40	-25 ... 40
Max. permissible radial shaft load F_q	N	80	80
Max. permissible axial shaft load F_a	N	30	30
Mass m	kg	1.05	1.05
Vibration strain as per DIN EN 60068-2-6	m/s ²	20	
Degree of protection as per DIN EN 60592		IP41	IP41
Heat class as per DIN EN 60034-1		155 (F)	155 (F)

Characteristic curves

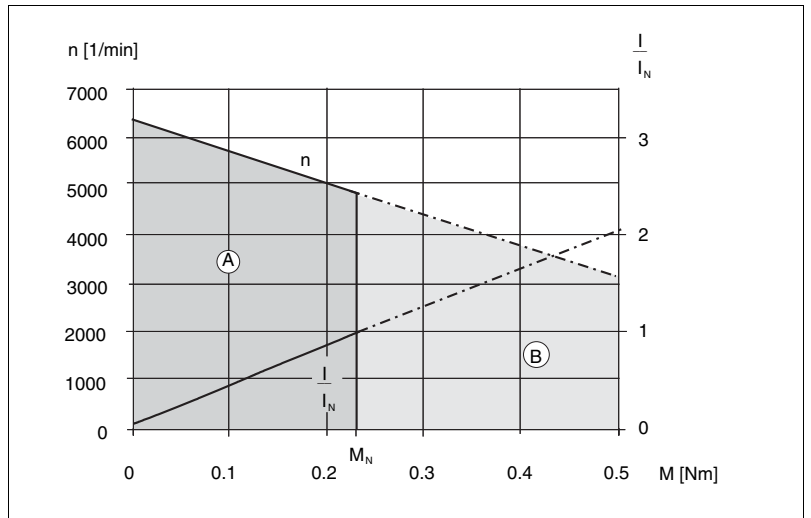

Torque characteristic BDM 722

(A) S1: continuous operation

(B) S2 ... S9: Short-term operation

Motor connection

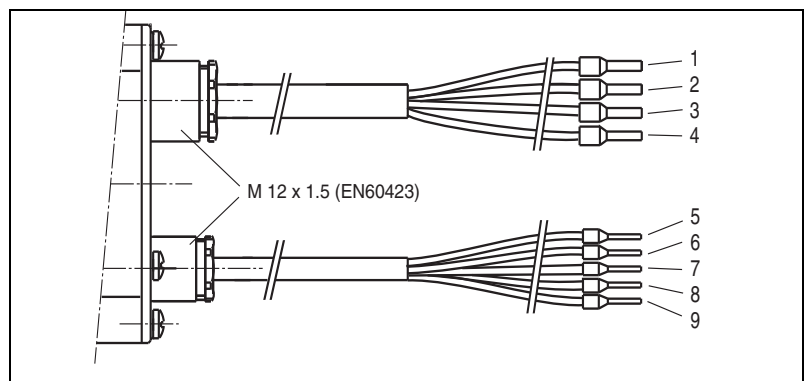

Terminal assignment

Pin	Motor cable	Colour
1	U	Orange (OG)
2	V	black (BK)
3	W	white (WS)
4	PE	green/yellow (GNYE)

Pin	Motor cable	Colour
5	Power supply 5 V ... 18 V	red (RD)
6	Power supply GND	blue (BU)
7	Hall U	orange (OG)
8	Hall V	black (BK)
9	Hall W	white (WH)

The pull-up resistance is not integrated. The maximum current at the Hall sensors is 30 mA.

BDM 724

Dimensional drawing

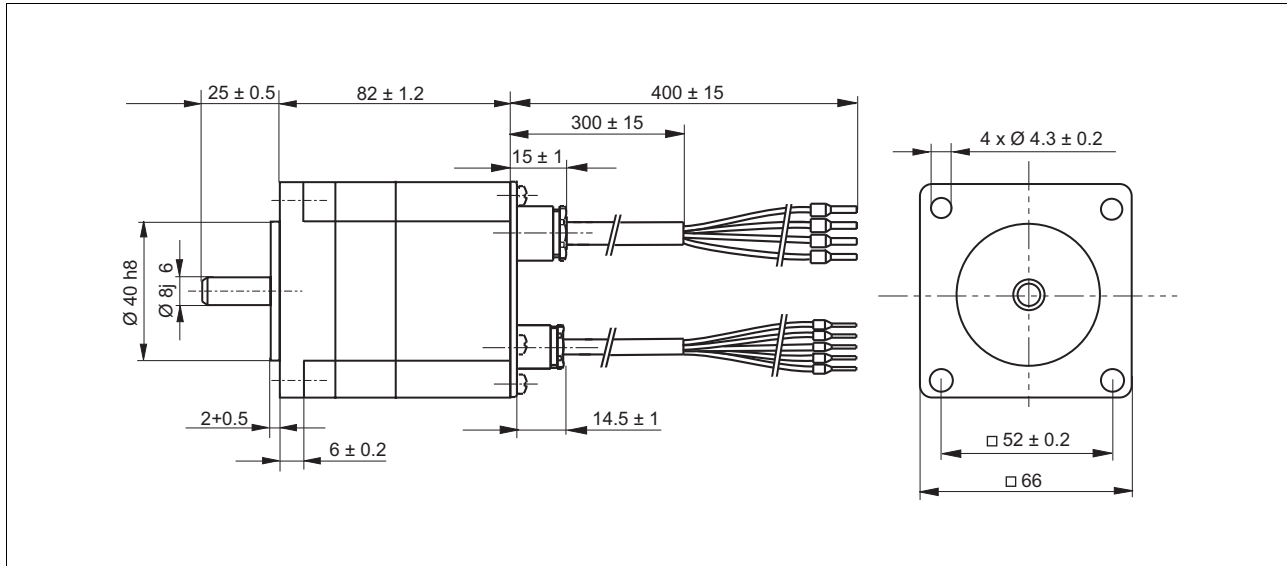

Dimensional drawing BDM 724

Technical data

DC bus voltage U_{DC}	V	24	48
Number of pole pairs p		4	4
Nominal power P_N	W	130	130
Nominal torque M_N	Nm	0.28	0.28
Nominal speed n_N	1/min	4350	4350
Nominal current I_N	A	8.1	4.03
Nominal current \hat{I}_N	A	9.9	4.93
No-load speed n_0	rpm	6500	6500
No-load current I_0	A	0.63	0.31
Continuous holding torque M_{d0}	Nm	0.33	0.33
Continuous holding current I_{d0}	A	9.1	4.70
Max. continuous holding current \hat{I}_{d0}	A	11.2	5.76
Max. torque M_{max}	Nm	0.70	0.70
Max. current I_{max}	A	20.7	10.3
Detent torque M_S	Nm	0.015	0.015
Torque constant (M_{d0}/\hat{I}_{d0}) k_M	Nm/A	0.030	0.057
Generator voltage constant k_{Ett}	mV/(1/min)	2.583	5.166
Terminal resistance R_{tt}	Ω	0.17	0.54
Terminal inductivity L_{tt}	mH	0.619	2.477
Rotor inertia J_R	kg cm ²	0.170	0.170
Heat resistance (winding/surface) R_{th1}	K/W	1.25	1.25
Ambient temperature	°C	-25 ... 40	-25 ... 40
Max. permissible radial shaft load F_q	N	80	80
Max. permissible axial shaft load F_a	N	30	30
Mass m	kg	1.05	1.05
Vibration strain as per DIN EN 60068-2-6	m/s ²	20	
Degree of protection as per DIN EN 60592		IP41	IP41
Heat class as per DIN EN 60034-1		155 (F)	155 (F)

Characteristic curves

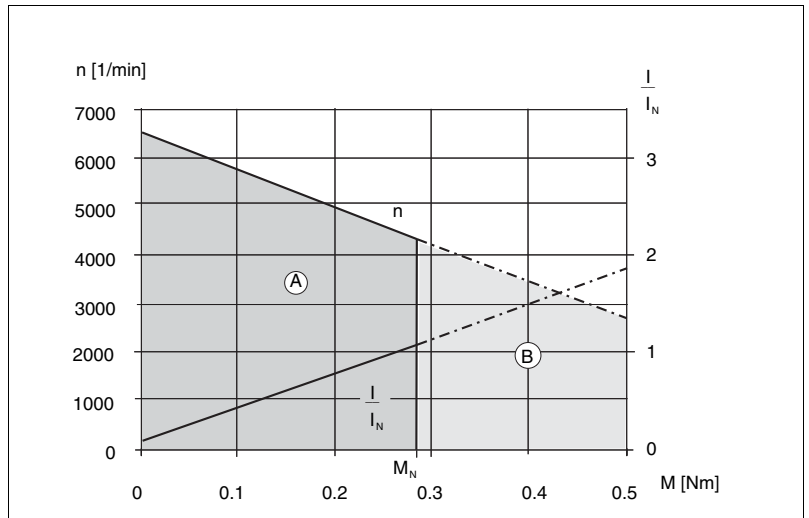

Torque characteristic BDM 724

(A) S1: continuous operation

(B) S2 ... S9: Short-term operation

Motor connection

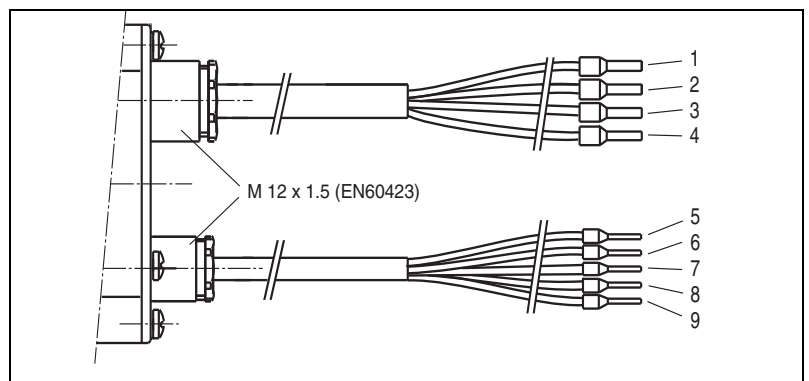

Terminal assignment

Pin	Motor cable	Colour
1	U	orange (OG)
2	V	black (BK)
3	W	white (WS)
4	PE	green/yellow (GNYE)

Pin	Motor cable	Colour
5	Power supply 5 V ... 18 V	red (RD)
6	Power supply GND	blue (BU)
7	Hall U	orange (OG)
8	Hall V	black (BK)
9	Hall W	white (WH)

The pull-up resistance is not integrated. The maximum current at the Hall sensors is 30 mA.

BDM 742

Dimensional drawing

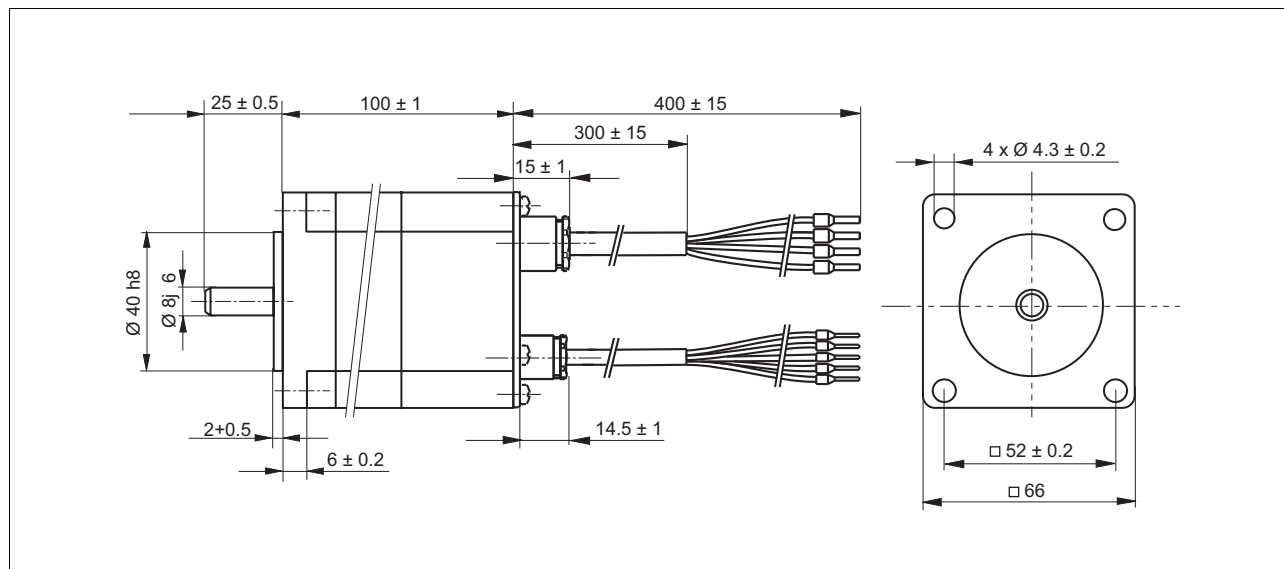

Dimensional drawing BDM 742

Technical data

DC bus voltage U_{DC}	V	24	48
Number of pole pairs p		2	2
Nominal power P_N	W	190	190
Nominal torque M_N	Nm	0.38	0.38
Nominal speed n_N	1/min	4750	4750
Nominal current I_N	A	9.7	4.84
Nominal current \hat{I}_N	A	11.9	5.93
No-load speed n_0	rpm	5800	5800
No-load current I_0	A	1.20	0.60
Continuous holding torque M_{d0}	Nm	0.53	0.53
Continuous holding current I_{d0}	A	13.1	6.87
Max. continuous holding current \hat{I}_{d0}	A	16.1	8.41
Max. torque M_{max}	Nm	1.40	1.40
Max. current I_{max}	A	37.1	18.5
Detent torque M_S	Nm	0.106	0.106
Torque constant (M_{d0}/\hat{I}_{d0}) k_M	Nm/A	0.033	0.064
Generator voltage constant k_{Ett}	mV/(1/min)	2.891	5.781
Terminal resistance R_{tt}	Ω	0.12	0.39
Terminal inductivity L_{tt}	mH	0.389	1.557
Rotor inertia J_R	kg cm ²	0.340	0.340
Heat resistance (winding/surface) R_{th1}	K/W	0.63	0.63
Ambient temperature	°C	-25 ... 40	-25 ... 40
Max. permissible radial shaft load F_q	N	80	80
Max. permissible axial shaft load F_a	N	30	30
Mass m	kg	1.4	1.4
Vibration strain as per DIN EN 60068-2-6	m/s ²	20	
Degree of protection as per DIN EN 60592		IP41	IP41
Heat class as per DIN EN 60034-1		155 (F)	155 (F)

Characteristic curves

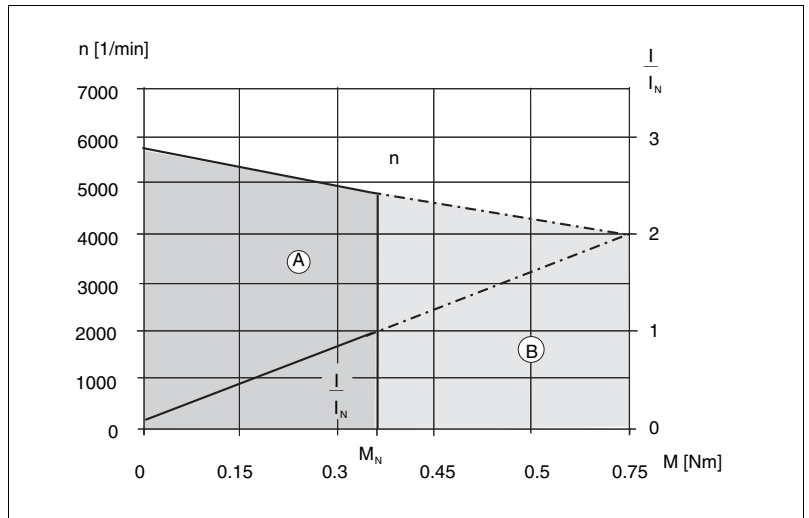

Torque characteristic BDM 742

(A) S1: continuous operation

(B) S2 ... S9: Short-term operation

Motor connection

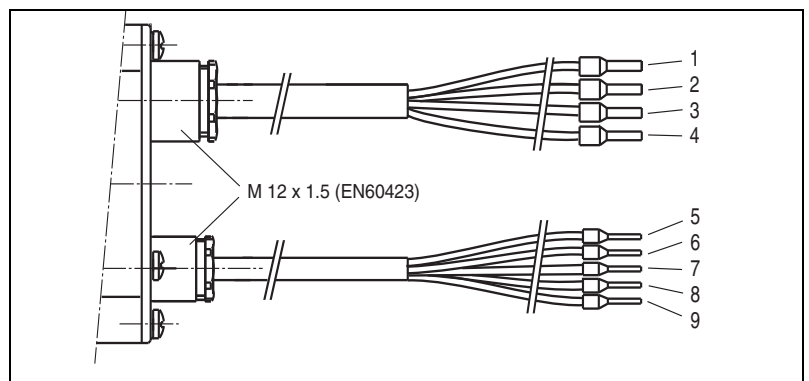

Terminal assignment

Pin	Motor cable	Colour
1	U	orange (OG)
2	V	black (BK)
3	W	white (WS)
4	PE	green/yellow (GNYE)

Pin	Motor cable	Colour
5	Power supply 5 V ... 18 V	red (RD)
6	Power supply GND	blue (BU)
7	Hall U	orange (OG)
8	Hall V	black (BK)
9	Hall W	white (WH)

The pull-up resistance is not integrated. The maximum current at the Hall sensors is 30 mA.

BDM 744

Dimensional drawing

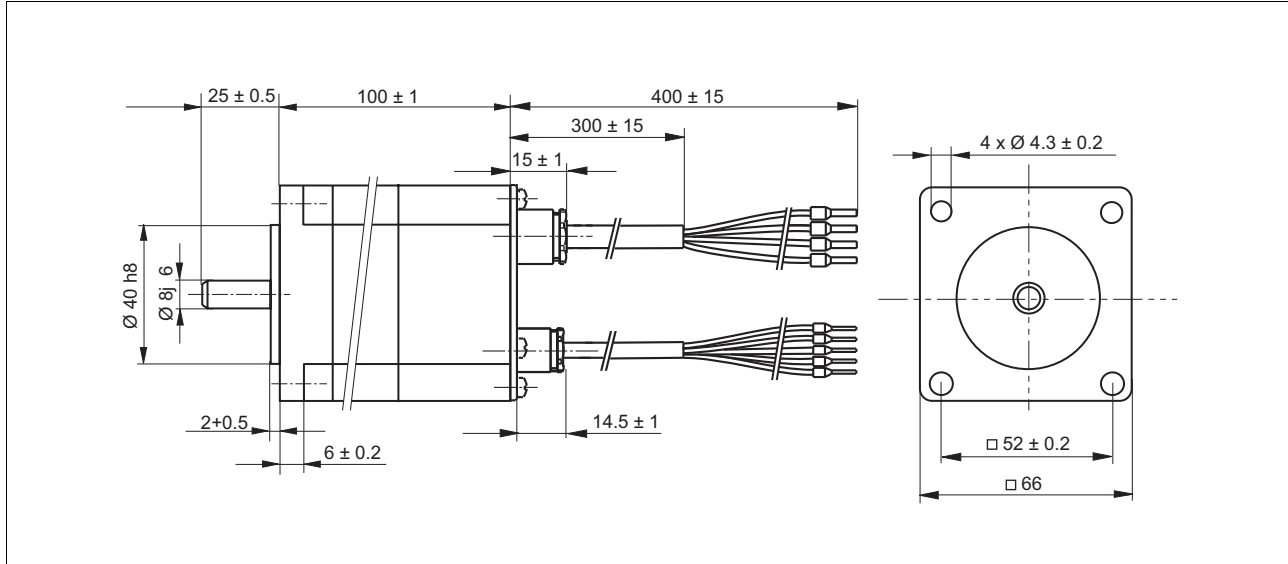

Dimensional drawing BDM 744

Technical data

DC bus voltage U_{DC}	V	24	48
Number of pole pairs p		4	4
Nominal power P_N	W	160	200
Nominal torque M_N	Nm	0.37	0.44
Nominal speed n_N	1/min	4250	4350
Nominal current I_N	A	9.2	5.54
Nominal current \hat{I}_N	A	11.3	6.78
No-load speed n_0	rpm	5800	5800
No-load current I_0	A	0.92	0.46
Continuous holding torque M_{d0}	Nm	0.58	0.58
Continuous holding current I_{d0}	A	11.9	7.29
Max. continuous holding current \hat{I}_{d0}	A	14.5	8.92
Max. torque M_{max}	Nm	1.40	1.40
Max. current I_{max}	A	36.5	18.3
Detent torque M_S	Nm	0.030	0.030
Torque constant (M_{d0}/\hat{I}_{d0}) k_M	Nm/A	0.040	0.065
Generator voltage constant k_{Ett}	mV/(1/min)	2.924	5.848
Terminal resistance R_{tt}	Ω	0.11	0.28
Terminal inductivity L_{tt}	mH	0.318	1.272
Rotor inertia J_R	kg cm ²	0.340	0.340
Heat resistance (winding/surface) R_{th1}	K/W	0.63	0.63
Ambient temperature	°C	-25 ... 40	-25 ... 40
Max. permissible radial shaft load F_q	N	80	80
Max. permissible axial shaft load F_a	N	30	30
Mass m	kg	1.4	1.4
Vibration strain as per DIN EN 60068-2-6	m/s ²	20	
Degree of protection as per DIN EN 60592		IP41	IP41
Heat class as per DIN EN 60034-1		155 (F)	155 (F)

Characteristic curves

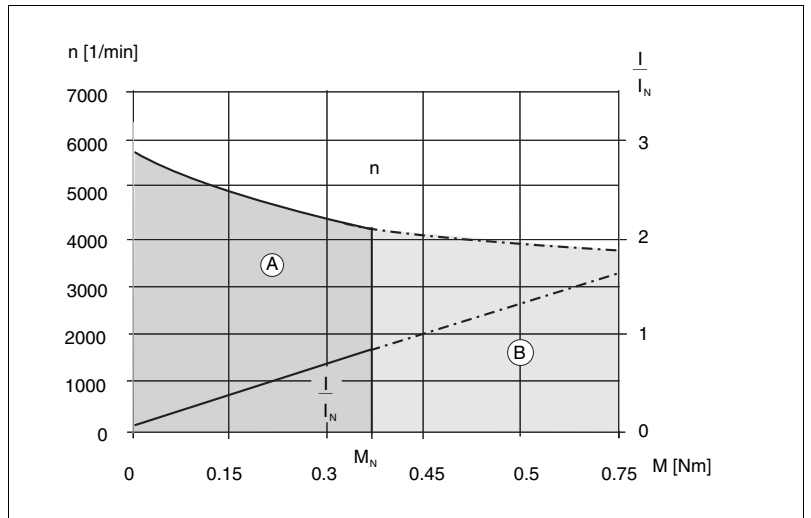

Torque characteristic BDM 744

- (A) S1: continuous operation
- (B) S2 ... S9: Short-term operation

Motor connection

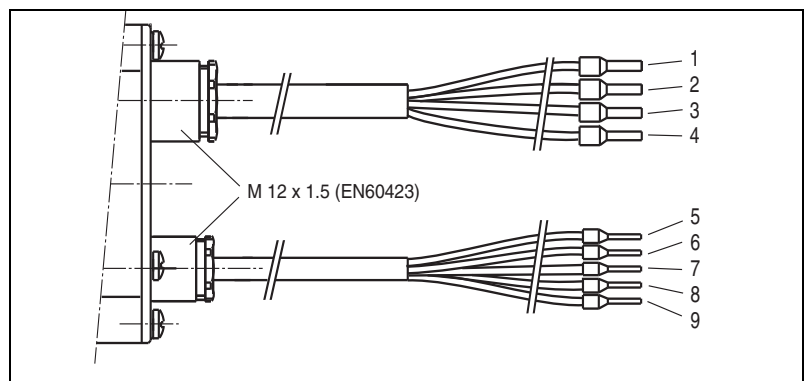

Terminal assignment

Pin	Motor cable	Colour
1	U	orange (OG)
2	V	black (BK)
3	W	white (WS)
4	PE	green/yellow (GNYE)

Pin	Motor cable	Colour
5	Power supply 5 V ... 18 V	red (RD)
6	Power supply GND	blue (BU)
7	Hall U	orange (OG)
8	Hall V	black (BK)
9	Hall W	white (WH)

The pull-up resistance is not integrated. The maximum current at the Hall sensors is 30 mA.

BDM 752

Dimensional drawing

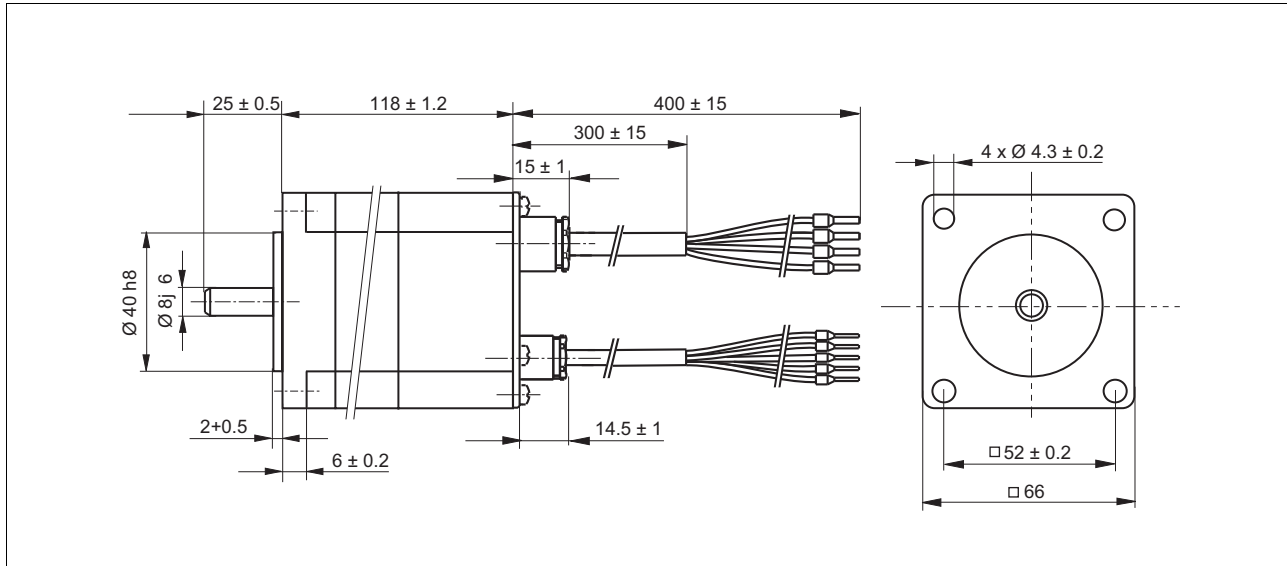

Dimensional drawing BDM 752

Technical data

DC bus voltage U_{DC}	V	48	60
Number of pole pairs p		2	2
Nominal power P_N	W	250	260
Nominal torque M_N	Nm	0.48	0.48
Nominal speed n_N	1/min	5000	5000
Nominal current I_N	A	6.37	5.2
Nominal current \hat{I}_N	A	7.8	6.3
No-load speed n_0	rpm	5900	5950
No-load current I_0	A	0.91	0.74
Continuous holding torque M_{d0}	Nm	0.81	0.81
Continuous holding current I_{d0}	A	10.51	8.7
Max. continuous holding current \hat{I}_{d0}	A	12.87	10.7
Max. torque M_{max}	Nm	2.10	2.10
Max. current I_{max}	A	28.2	22.8
Detent torque M_S	Nm	0.158	0.158
Torque constant (M_{d0}/\hat{I}_{d0}) k_M	Nm/A	0.077	0.092
Generator voltage constant k_{Ett}	mV/(1/min)	5.699	7.062
Terminal resistance R_{tt}	Ω	0.22	0.31
Terminal inductivity L_{tt}	mH	0.925	1.420
Rotor inertia J_R	kg cm ²	0.510	0.510
Heat resistance (winding/surface) R_{th1}	K/W	0.42	0.42
Ambient temperature	°C	-25 ... 40	-25 ... 40
Max. permissible radial shaft load F_q	N	80	80
Max. permissible axial shaft load F_a	N	30	30
Mass m	kg	1.7	1.7
Vibration strain as per DIN EN 60068-2-6	m/s ²	20	
Degree of protection as per DIN EN 60592		IP41	IP41
Heat class as per DIN EN 60034-1		155 (F)	155 (F)

Characteristic curves

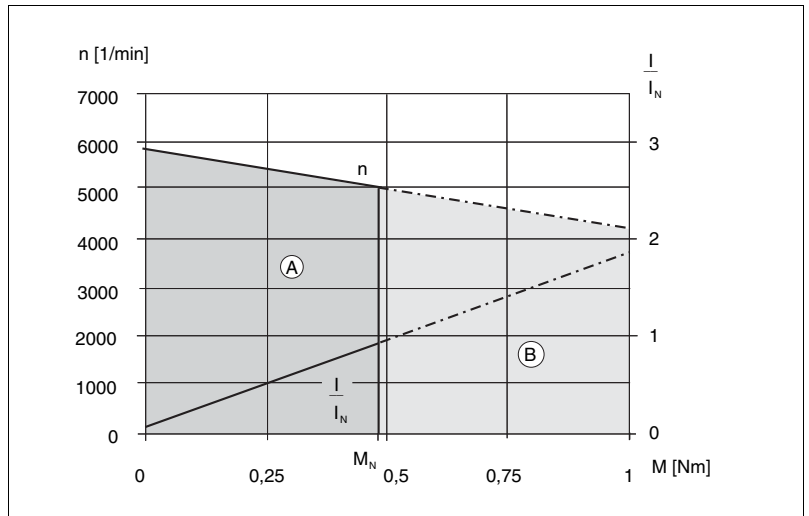

Torque characteristic BDM 752

(A) S1: continuous operation

(B) S2 ... S9: Short-term operation

Motor connection

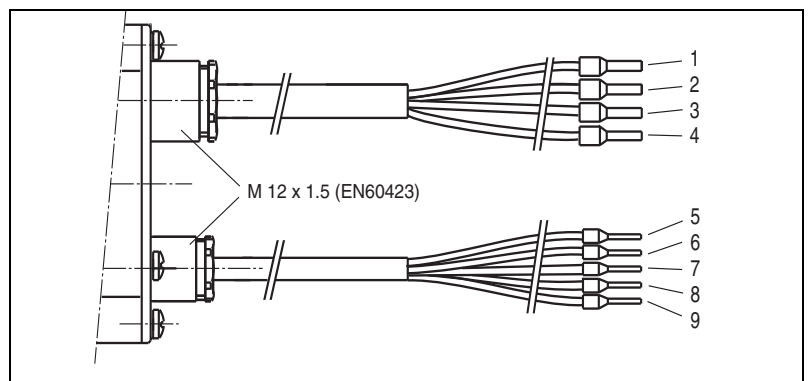

Terminal assignment

Pin	Motor cable	Colour
1	U	orange (OG)
2	V	black (BK)
3	W	white (WS)
4	PE	green/yellow (GNYE)

Pin	Motor cable	Colour
5	Power supply 5 V ... 18 V	red (RD)
6	Power supply GND	blue (BU)
7	Hall U	orange (OG)
8	Hall V	black (BK)
9	Hall W	white (WH)

The pull-up resistance is not integrated. The maximum current at the Hall sensors is 30 mA.

BDM 754

Dimensional drawing

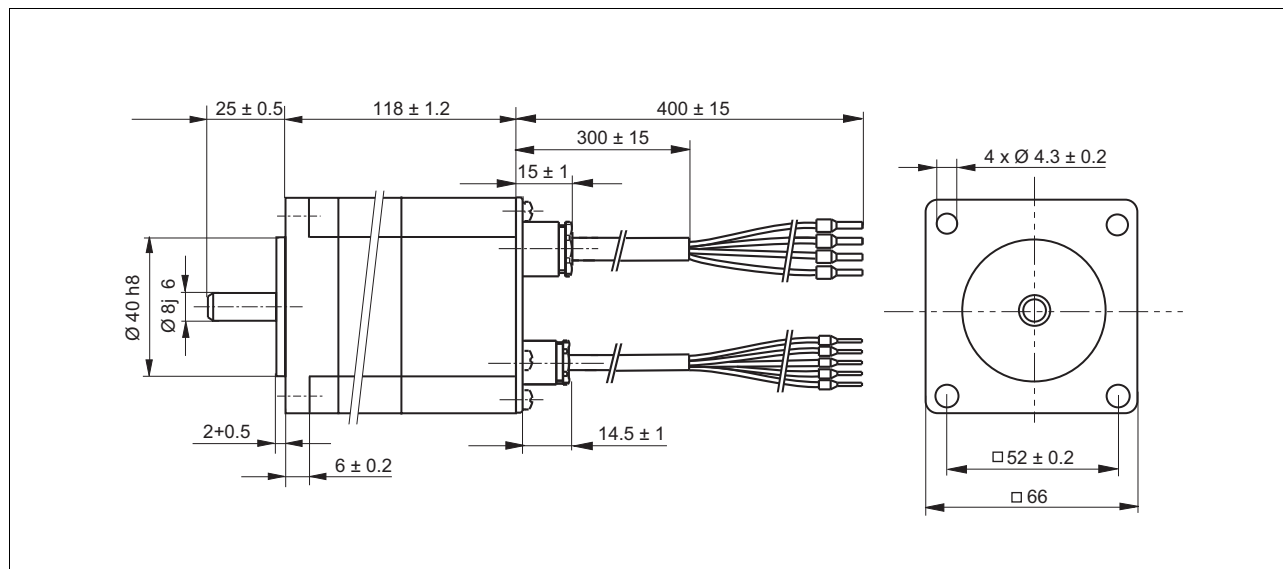

Dimensional drawing BDM 754

Technical data

DC bus voltage U_{DC}	V	48	60
Number of pole pairs p		4	4
Nominal power P_N	W	310	310
Nominal torque M_N	Nm	0.68	0.68
Nominal speed n_N	1/min	4350	4350
Nominal current I_N	A	8.42	6.7
Nominal current \hat{I}_N	A	10.31	8.2
No-load speed n_0	rpm	5850	5850
No-load current I_0	A	0.63	0.51
Continuous holding torque M_{d0}	Nm	0.88	0.88
Continuous holding current I_{d0}	A	11.10	9.1
Max. continuous holding current \hat{I}_{d0}	A	13.59	11.1
Max. torque M_{max}	Nm	2.10	2.10
Max. current I_{max}	A	27.4	21.9
Detent torque M_S	Nm	0.045	0.045
Torque constant (M_{d0}/\hat{I}_{d0}) k_M	Nm/A	0.065	0.079
Generator voltage constant k_{Ett}	mV/(1/min)	5.848	7.311
Terminal resistance R_{tt}	Ω	0.18	0.25
Terminal inductivity L_{tt}	mH	0.778	1.215
Rotor inertia J_R	kg cm ²	0.510	0.510
Heat resistance (winding/surface) R_{th1}	K/W	0.42	0.42
Ambient temperature	°C	-25 ... 40	-25 ... 40
Max. permissible radial shaft load F_q	N	80	80
Max. permissible axial shaft load F_a	N	30	30
Mass m	kg	1.7	1.7
Vibration strain as per DIN EN 60068-2-6	m/s ²	20	
Degree of protection as per DIN EN 60592		IP41	IP41
Heat class as per DIN EN 60034-1		155 (F)	155 (F)

Characteristic curves

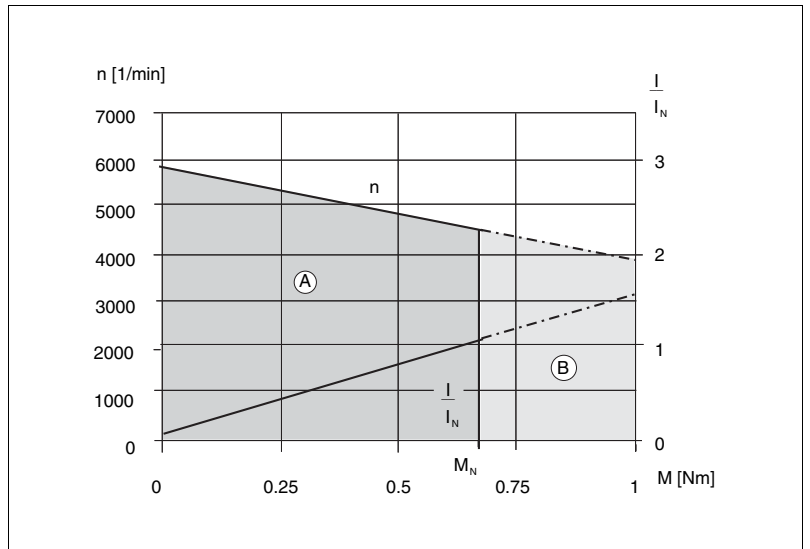

Torque characteristic BDM 754

(A) S1: continuous operation

(B) S2 ... S9: Short-term operation

Motor connection

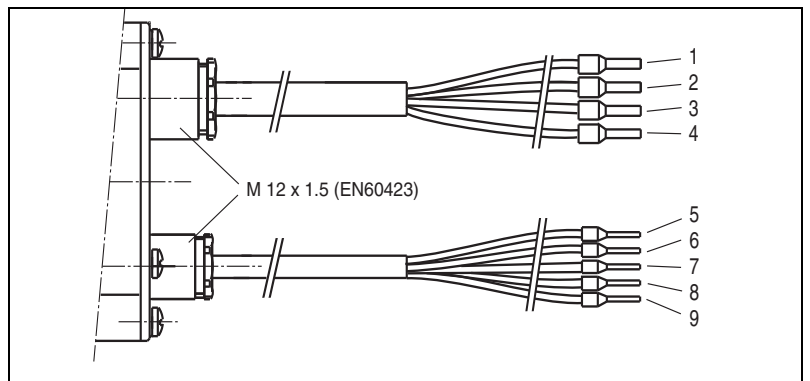

Terminal assignment

Pin	Motor cable	Colour
1	U	orange (OG)
2	V	black (BK)
3	W	white (WS)
4	PE	green/yellow (GNYE)

Pin	Motor cable	Colour
5	Power supply 5 V ... 18 V	red (RD)
6	Power supply GND	blue (BU)
7	Hall U	orange (OG)
8	Hall V	black (BK)
9	Hall W	white (WH)

The pull-up resistance is not integrated. The maximum current at the Hall sensors is 30 mA.

BDM 772

Dimensional drawing

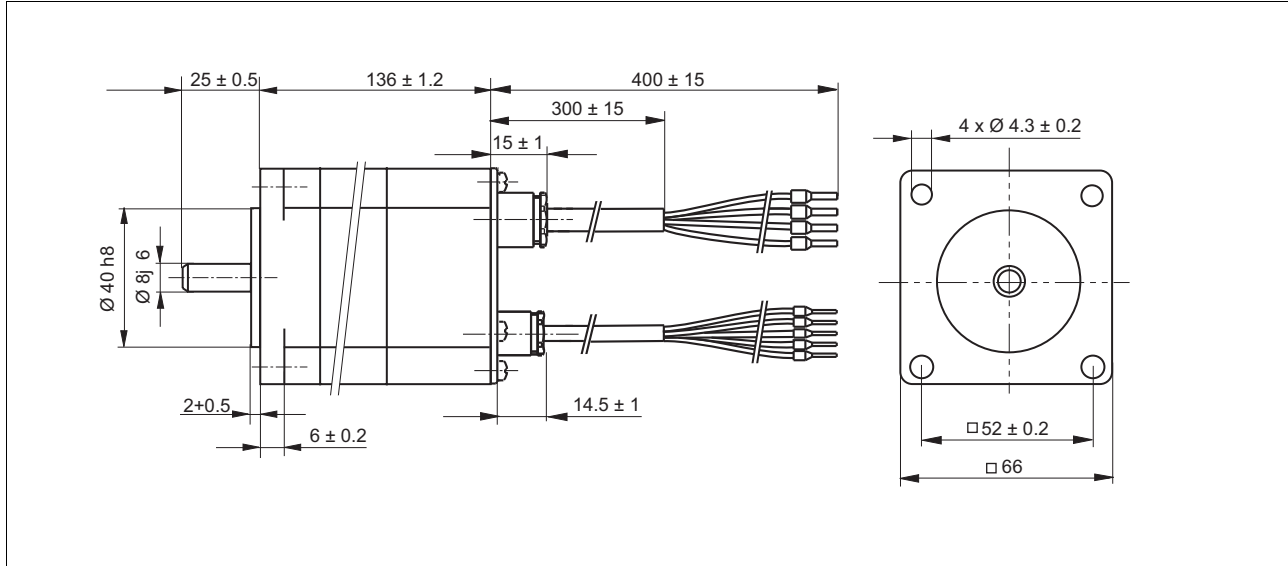

Dimensional drawing BDM 772

Technical data

DC bus voltage U_{DC}	V	48	60
Number of pole pairs p		2	2
Nominal power P_N	W	350	370
Nominal torque M_N	Nm	0.67	0.67
Nominal speed n_N	1/min	5000	5300
Nominal current I_N	A	8.91	8.0
Nominal current \hat{I}_N	A	10.92	9.8
No-load speed n_0	rpm	6000	6350
No-load current I_0	A	1.24	1.12
Continuous holding torque M_{d0}	Nm	1.08	1.08
Continuous holding current I_{d0}	A	14.33	13.0
Max. continuous holding current \hat{I}_{d0}	A	17.55	15.9
Max. torque M_{max}	Nm	2.80	2.80
Max. current I_{max}	A	38.2	32.4
Detent torque M_S	Nm	0.211	0.211
Torque constant (M_{d0}/\hat{I}_{d0}) k_M	Nm/A	0.062	0.068
Generator voltage constant k_{Ett}	mV/(1/min)	5.616	6.607
Terminal resistance R_{tt}	Ω	0.16	0.21
Terminal inductivity L_{tt}	mH	0.643	0.891
Rotor inertia J_R	kg cm ²	0.680	0.680
Heat resistance (winding/surface) R_{th1}	K/W	0.31	0.31
Ambient temperature	°C	-25 ... 40	-25 ... 40
Max. permissible radial shaft load F_q	N	80	80
Max. permissible axial shaft load F_a	N	30	30
Mass m	kg	2.05	2.05
Vibration strain as per DIN EN 60068-2-6	m/s ²	20	
Degree of protection as per DIN EN 60592		IP41	IP41
Heat class as per DIN EN 60034-1		155 (F)	155 (F)

Characteristic curves

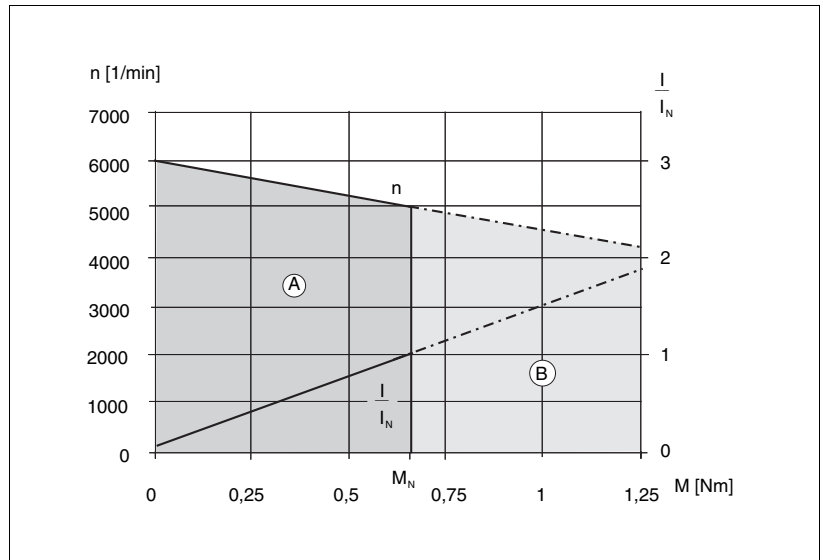

Torque characteristic BDM 772

(A) S1: continuous operation

(B) S2 ... S9: Short-term operation

Motor connection

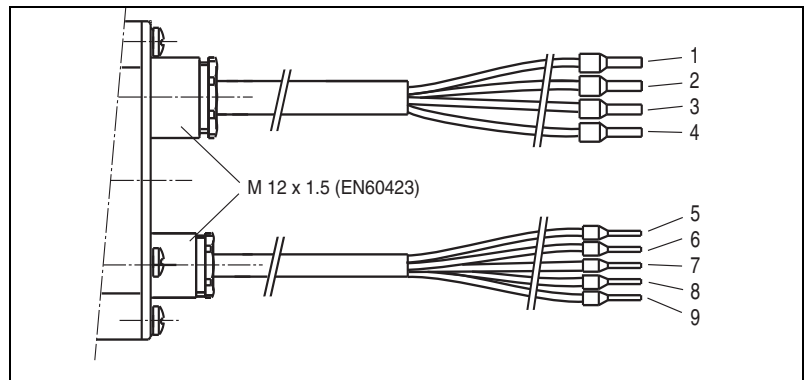

Terminal assignment

Pin	Motor cable	Colour
1	U	orange (OG)
2	V	black (BK)
3	W	white (WS)
4	PE	green/yellow (GNYE)

Pin	Motor cable	Colour
5	Power supply 5 V ... 18 V	red (RD)
6	Power supply GND	blue (BU)
7	Hall U	orange (OG)
8	Hall V	black (BK)
9	Hall W	white (WH)

The pull-up resistance is not integrated. The maximum current at the Hall sensors is 30 mA.

BDM 774

Dimensional drawing

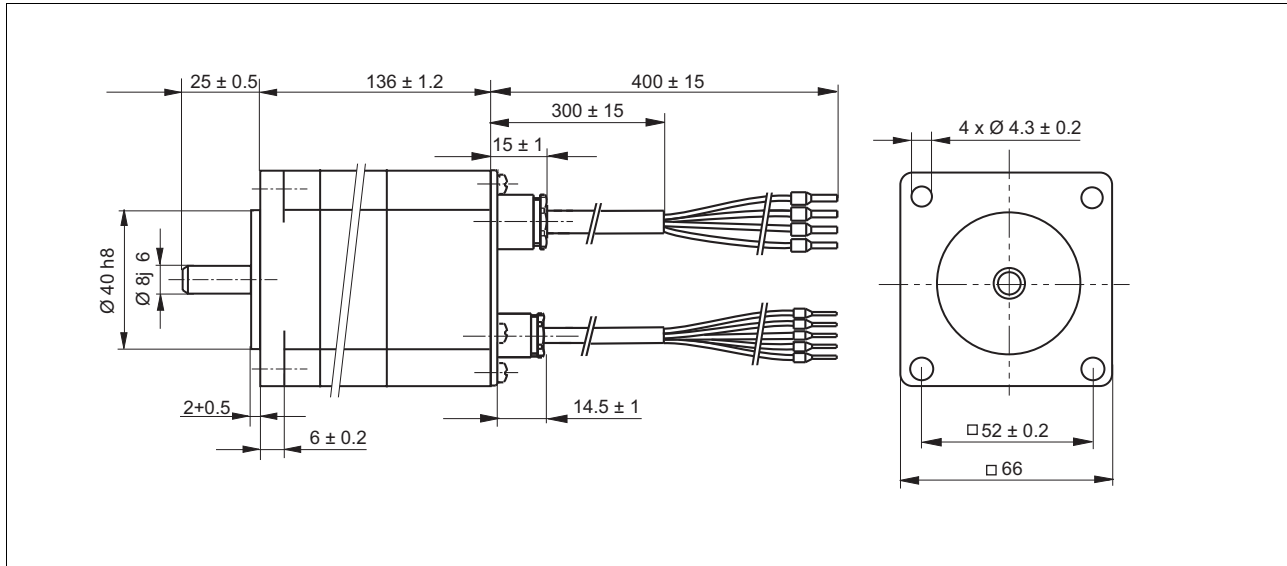

Dimensional drawing BDM 774

Technical data

DC bus voltage U_{DC}	V	48	60
Number of pole pairs p		4	4
Nominal power P_N	W	370	360
Nominal torque M_N	Nm	0.80	0.80
Nominal speed n_N	1/min	4450	4350
Nominal current I_N	A	9.94	7.7
Nominal current \hat{I}_N	A	12.17	9.4
No-load speed n_0	rpm	5850	5750
No-load current I_0	A	0.83	0.64
Continuous holding torque M_{d0}	Nm	1.09	1.09
Continuous holding current I_{d0}	A	13.69	11.0
Max. continuous holding current \hat{I}_{d0}	A	16.76	13.5
Max. torque M_{max}	Nm	2.80	2.80
Max. current I_{max}	A	36.5	28.8
Detent torque M_S	Nm	0.060	0.060
Torque constant (M_{d0}/\hat{I}_{d0}) k_M	Nm/A	0.065	0.081
Generator voltage constant k_{Ett}	mV/(1/min)	5.848	7.408
Terminal resistance R_{tt}	Ω	0.15	0.21
Terminal inductivity L_{tt}	mH	0.577	0.849
Rotor inertia J_R	kg cm ²	0.680	0.680
Heat resistance (winding/surface) R_{th1}	K/W	0.31	0.31
Ambient temperature	°C	-25...40	-25 ... 40
Max. permissible radial shaft load F_q	N	80	80
Max. permissible axial shaft load F_a	N	30	30
Mass m	kg	2.05	2.05
Vibration strain as per DIN EN 60068-2-6	m/s ²	20	
Degree of protection as per DIN EN 60592		IP41	IP41
Heat class as per DIN EN 60034-1		155 (F)	155 (F)

Characteristic curves

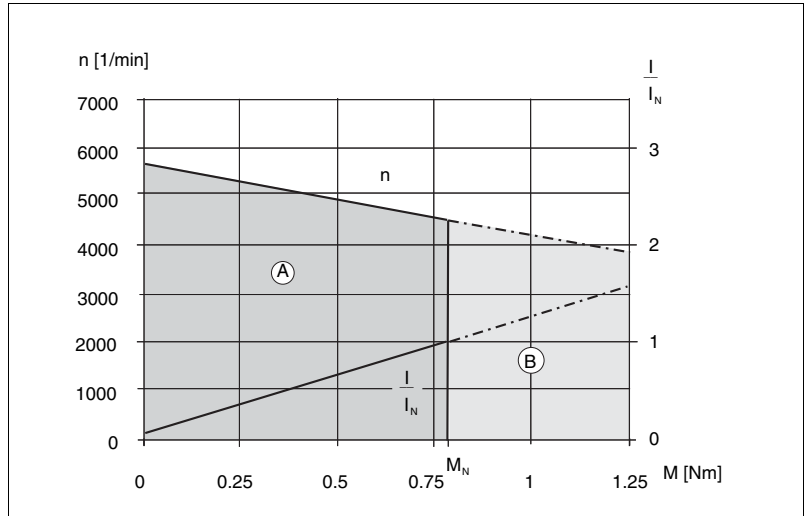

Torque characteristic BDM 774

(A) S1: continuous operation

(B) S2 ... S9: Short-term operation

Motor connection

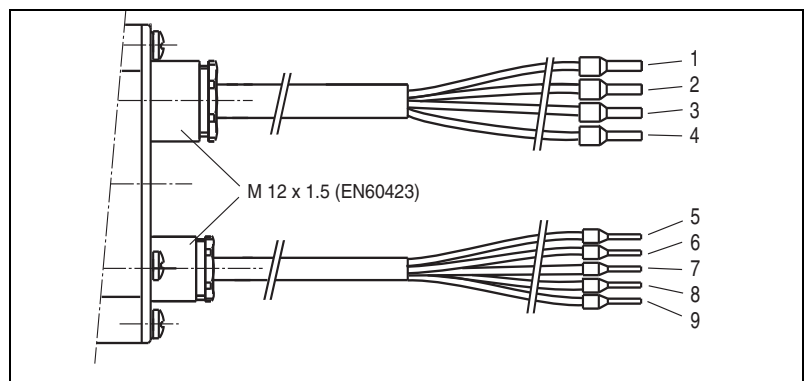

Terminal assignment

Pin	Motor cable	Colour
1	U	orange (OG)
2	V	black (BK)
3	W	white (WS)
4	PE	green/yellow (GNYE)

Pin	Motor cable	Colour
5	Power supply 5 V ... 18 V	red (RD)
6	Power supply GND	blue (BU)
7	Hall U	orange (OG)
8	Hall V	black (BK)
9	Hall W	white (WH)

The pull-up resistance is not integrated. The maximum current at the Hall sensors is 30 mA.

BDM 7• options

BDM 72• and BDM 74• with spurwheel gearbox

Dimensional drawing

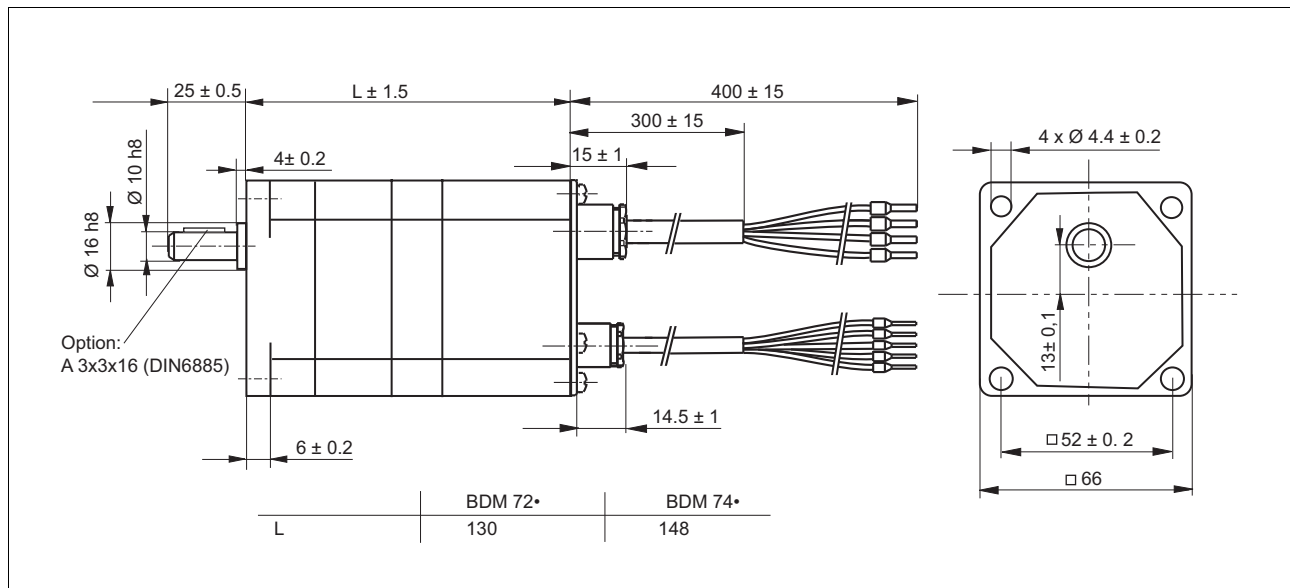

Dimensional drawing of BDM 72• and BDM 74• with spur wheel gear

Technical data

Gear ratio		7	18	38	54	115
Gear stages		2	3	3	4	4
Max. continuous torque	Nm	2.5	3.5	6	6	8
Efficiency	%	85	80	80	75	75
Permissible radial force	N	200	200	200	200	200
Permissible axial force	N	10	10	10	10	10
Housing and teeth		Steel				
Drive shaft		Hardened smooth or with feather key DIN 6885				
Seal at shaft exit		Shaft seal ring IP54				
Max. recommended input speed	1/min	3000				
Maximum torsional backlash	°	< 1.5	< 1			
Operating temperature	°C	-15 ... +65				
Expected service life	h	average 2500, depending on load profile				

Note: The spur wheel gear cannot be combined with the holding brake.

BDM 7• with planetary gearbox PM62

Dimensional drawing

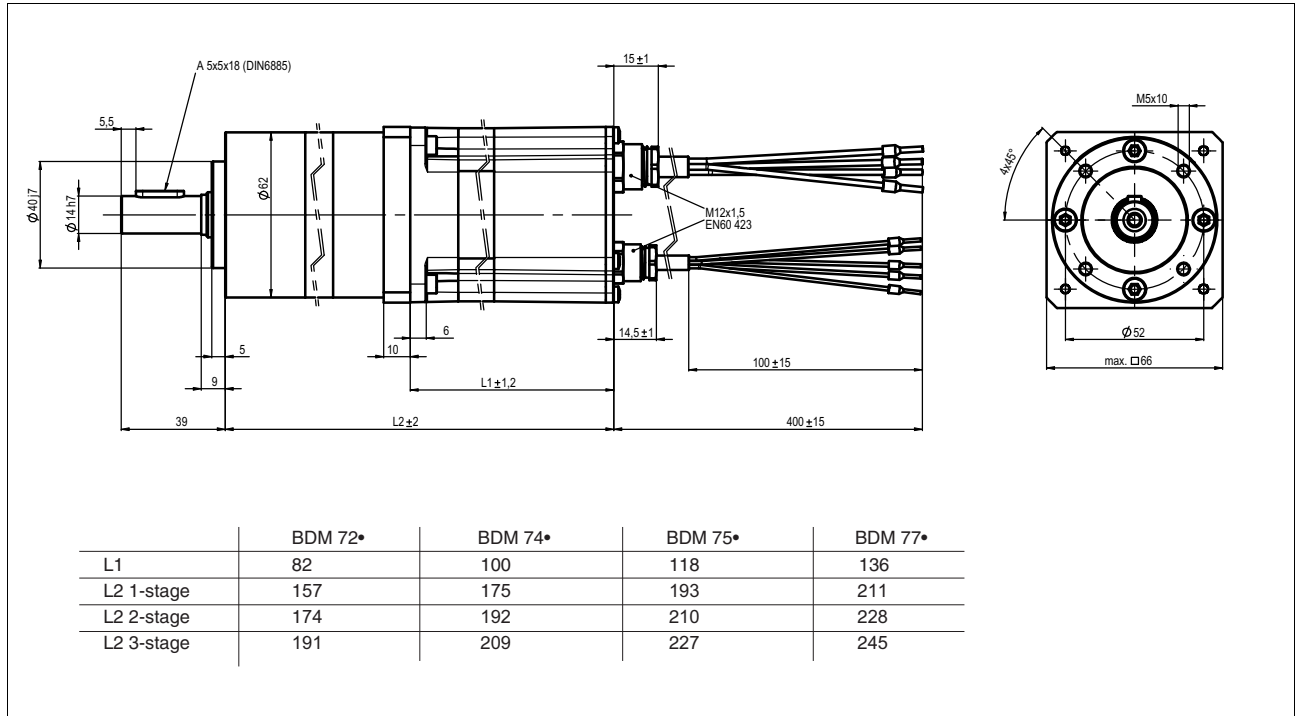

Dimensional drawing BDM 7• with yellow planetary gear PM62

Technical data

		7 (6.75)	25 (25.01)	46 (45.56)	93 (92.7)	115 (115.07)	308 (307.54)
Gear ratio							
Gear stages		1	2	2	3	3	3
Max. continuous torque	Nm	8	25	25	50	50	50
Efficiency	%	80	75	75	70	70	70
Permissible radial force	N	240	360	360	520	520	520
Permissible axial force	N	70	100	100	150	150	150
Housing and teeth		Steel					
Drive shaft		Hardened smooth or with feather key DIN 6885					
Seal at shaft exit		Shaft seal ring IP54					
Max. recommended input speed	1/min	3000					
Maximum torsional backlash	°	0.65	0.7		0.75		
Operating temperature	°C	-30 ... +140					
Expected service life	h	average 3500, depending on load profile					

BDM 7• with encoder

Dimensional drawing

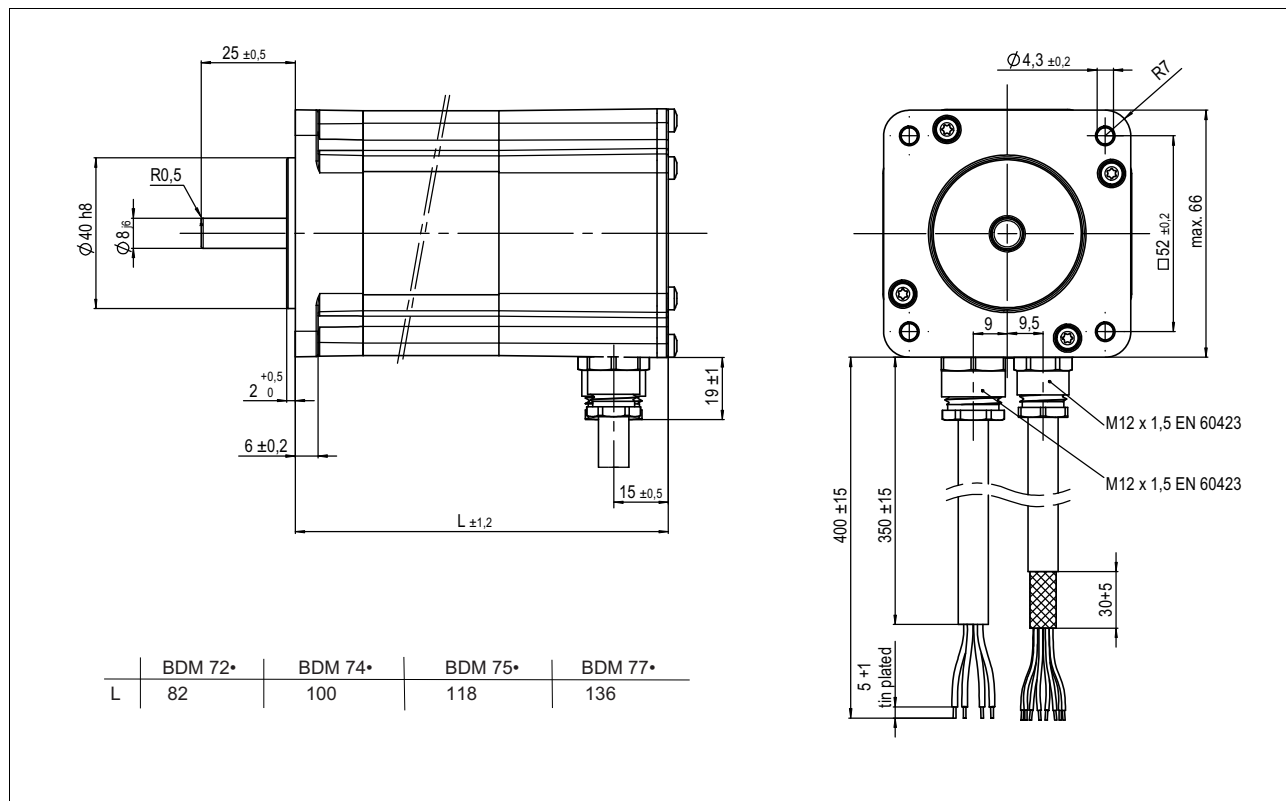

Dimensional drawing BDM 7• with encoder

- (A) Motor connection, Helucabel JZ-602-CY, 4 x AWG 18
 motor U black 1 (BK1)
 motor V black 2 (BK2)
 motor W black 3 (BK3)
 PE earth green/yellow (GN/YE)
- (B) Encoder connection

Assignment information Encoder on BDM 7•

Designation color:

Connection	Wire colour as per DIN IEC 757	Wire colour
VCC Encoder +5V		red
GND Encoder		black
N.C ¹⁾		grey
A	YE	yellow
A-		yellow/white
B	BU	blue
B-		blue/white
Index		orange
Index-		orange/white
Hall U		green
Hall U-		green/white
Hall V	BK	brown
Hall V-	BK	brown/white
Hall W	WH	white
Hall W-	WH	grey/white

¹⁾ not connection

Encoder

The BDM 7• motors can be supplied with a digital encoder as an option. This encoder is an optical incremental encoder with the following features:

- Encoder integrated in motor
- Second shaft end available on request
- Line count 500 / 1000
- With 4 or 8-pin commutation signals
- Hall sensor connections included in encoder connection

Technical data

Output signals		5V Open Collector or RS 422
Operating temperature	°C	-40 ... +120
Max. speed	1/min	12000

BDM 7• with holding brake

Dimensional drawing

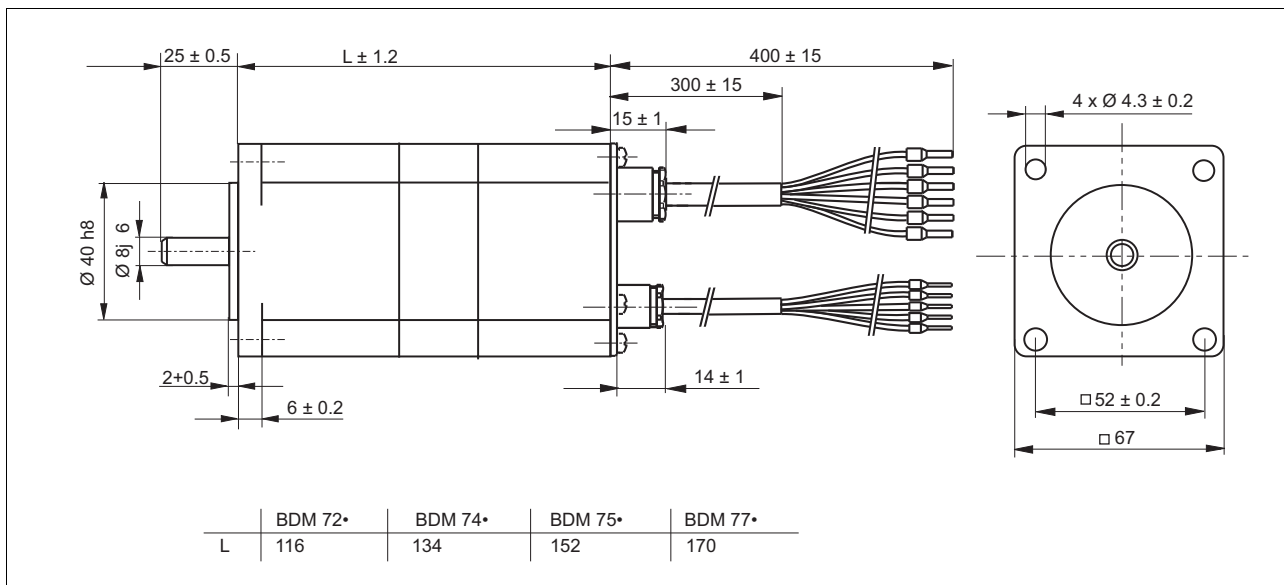

Dimensional drawing BDM 7• with holding brake

Motor connection

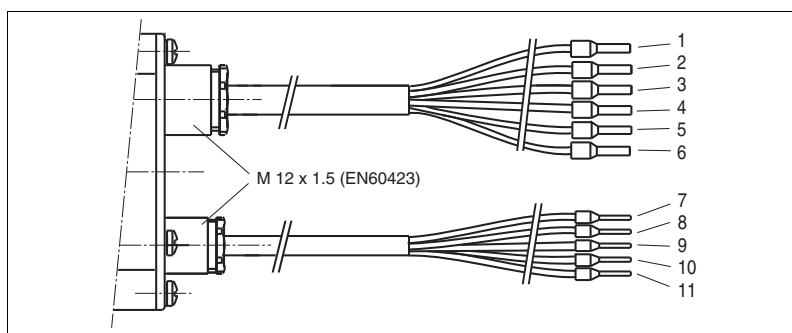

Terminal assignment BDM 7• with holding brake

Pin	Connection	Wire colour as per IEC 60757	Wire colour
Motor cable			
1	U	OG	orange
2	V	BK	black
3	W	WH	white
4	PE	GNYE	green/yellow
Holding brake cable			
5	Power supply 24 V	RD	red
6	Power supply GND	BU	blue
Signal cable			
7	Power supply 5 ... 18 V	RD	red
8	Power supply GND	BU	blue
9	Hall U	OG	orange
10	Hall V	BK	black
11	Hall W	WH	white

The pull-up resistance is not integrated. The maximum current at the Hall sensors is 30 mA.

Holding brake

The BDM 7• motors can be supplied with a holding brake as an option. The holding brake is an electromagnetic sprung brake for holding the motor axis.

Features:

- Brake integrated in motor
- Holds the motor in position at standstill (no service brake)
- For safety after switching off the motor current, e.g. on EMERGENCY STOP (current = open, no current = closed)

Note: the holding brake cannot be combined with the spur wheel gear.

Technical data

Rated currency	V	24
Rated Power	W	7.5
Ambient temperature	°C	-5 ... +120
Holding torque M _H	Nm	1.1
Max. speed	1/min	10.000
Mass	kg	0.23

BDM 7• type code

Example:	BDM	72	2	2	5	C	A	00
Product family BDM = Brushless DC Motor	BDM	72	2	2	5	C	A	00
Motor size / Motor length 72 = 66 mm / 18 mm 74 = 66 mm / 36 mm 75 = 66 mm / 54 mm 77 = 66 mm / 72 mm	BDM	72	2	2	5	C	A	00
Number of Polpairs / Holding Torque 2 = 2 poles / High holding torque 4 = 4 poles / Low holding torque	BDM	72	2	2	5	C	A	00
Voltage 2 = 24 V only for motor size/motor length 72, 74 4 = 48 V only for motor size/motor length 72, 74, 75, 77 6 = 60 V only for motor size/motor length 75, 77			2	2	5	C		
Feedback system and Resolution H = Hall-Sensor 5 = Incremental Encoder with 1000 increments ^{1) 5) 6)}	BDM	72	2	2	5	C	A	00
Electrical connection A = Braided wires C = Cable ²⁾	BDM	72	2	2	5	C	A	00
Holding brake A = without brake F = with brake	BDM	72	2	2	5	C	A	00
Shaft model / Gearbox type / Gear ratio 00 = without gearbox with spur wheel gear: ^{3) 4)} V1 = 7:1 V2 = 18:1 V3 = 36:1 V4 = 54:1 V5 = 115:1 with planetary gear gear PM62: Q1 = 7:1 (6.75) Q2 = 25:1 (25.01) Q3 = 46:1 (45.56) Q4 = 93:1 (92.7) Q5 = 115:1 (115.07) Q6 = 308:1 (307.54)	BDM	72	2	2	5	C	A	00

- ¹⁾ only with electrical connection = C
- ²⁾ only motor with encoder / holding brake + encoder
- ³⁾ not possible in connection with a holding brake
- ⁴⁾ for BDM 72 and BDM 74 only
- ⁵⁾ only with numbers of polpairs = 4
- ⁶⁾ other resolutions on request

Accessories

Motor cable for BDM 4• motors

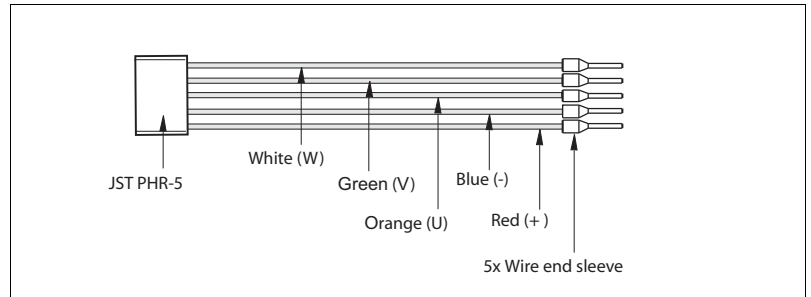

Connector cable for Hall sensors for BDM 4•

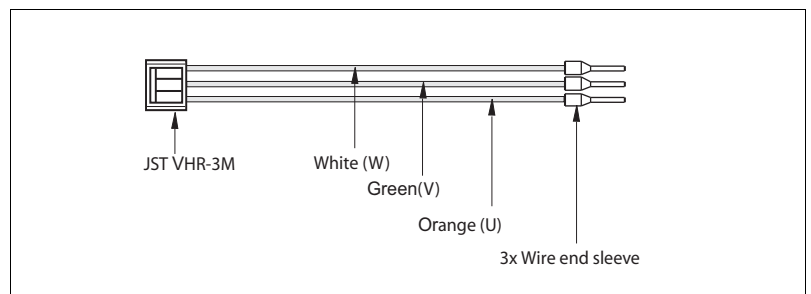

Connector cable for motor power supply for BDM 4•

Order data – general overview

Designation	Description	Order number	
BLP 14			
Adapter	For DIN rail mounting	VW3M2709	
Connector kit BLP, CANopen	Spring cage cable connectors for all device connections	VW3M4707	
Connector kit BLP, CANopen + I/O extension	Spring cage cable connectors for all device connections	VW3M4708	
Braking resistor controller UBC 60	For connection of a braking resistor that protects the device against overvoltage.	ACC3EA001	
Remote terminal (HMI)	For remote configuration, setting and control of the drive and remote display of the device parameters	VW3A31101	
EMC Kit	For shield connection of shielded cables	VW3M4710	
Holding brake controller HBC	For connection of holding brakes with 24V / 1.6A	VW3M3103	
PC connection kit	RS485 to RS232 converter	VW3A8106	
BLV 14			
Adapter	For DIN rail mounting	VW3M2709	
Connector kit BLV	Spring cage cable connectors for all device connections, 2, 4, 6 and 10 pins	VW3M4706	
EMC kit	For shield connection of shielded cables	VW3M4710	
Braking resistor controller UBC 60	For connection of a braking resistor that protects the device against overvoltage.	ACC3EA001	
Motor cable for BDM 4•			
Connection cable Hall effect sensors	Sensor cable, wire version, 5-pin flat connector at motor end and wire ferrules at the other end for connection of the Hall effect sensors	0.3 m	VW3M4702
Connection cable Hall effect sensors		3 m	VW3M4703
Connection cable motor supply	Motor cable, wire version, 3-pin flat connector at motor end and wire ferrules at the other end for connection of the Hall effect sensors	0.3 m	VW3M4704
Connection cable motor supply		3 m	VW3M4711

Power supply units for BLV

Power supply units can be purchased from Telemecanique (www.telemecanique.com).

The stabilised power supply units of the ABL1 and ABL2 series are suitable.

GBX planetary gearboxes

Presentation

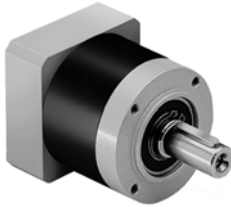

In many cases the axis controller requires the use of a planetary gearbox for adjustment of speed of rotation and torque; the accuracy required by the application must be maintained.

Schneider Electric Motion has chosen to use GBX 60 gearbox (made by Neugart) with the BDM motors. These gearboxes are lubricated for life and are designed for applications which are not susceptible to mechanical backlash. The fact that their use in combination with BDM motors has been fully verified and that they are easily assembled, ensures simple, risk-free operation.

The GBX 60 gearboxes are offered in 4 reduction ratios (16:1, 40:1, 60:1, 120:1), see table below.

The values for the continuous torque and the peak torque at standstill which are available at the output shaft, are calculated by multiplying the motor characteristics with the gear ratio and the efficiency of the gearing (0.94 or 0.90 depending on the reduction ratio).

The following table shows the optimum combination of BDM motor and GBX planetary gearbox.

BDM Brushless DC Motor/GBX gearbox combinations				
BDM 7•	Reduction ratio			
	16:1	40:1	60:1	120:1
BDM 72•	GBX 60	GBX 60	GBX 60	GBX 60
BDM 74•	GBX 60	GBX 60	GBX 60	GBX 60
BDM 75•	GBX 60	GBX 60	GBX 60	GBX 60
BDM 77•	GBX 60	GBX 60	GBX 60	GBX 60

GBX 60 *For these combinations, you must check that the application will not exceed the maximum output torque of the gearbox.*

Technical data			
Version			Planetary gearbox with straight teethL
Backlash	16:1 ... 40:1	arcmin	< 15
	60:1 ... 120:1		< 18
Torsional rigidity	16:1 ... 40:1	Nm/ arcmin	2.5
	60:1 ... 120:1		2.2
Noise level ¹⁾			58
Casing			Steel, black surface
Shaft material			C 45
Shaft output dust and dump protection			IP 54
Lubrication			Lifetime lubrication
Average service life ²⁾		h	30000
Mounting position			Any position
Operating temperature		°C	-25 ... +90
Efficiency	16:1 ... 40:1		0,94
	60:1 ... 120:1		0,90
Maximum permitted radial force ^{2) 3)}	L _{10h} = 10000 h	N	500
	L _{10h} = 30000 h	N	340
Maximum permitted axial force ²⁾	L _{10h} = 10000 h	N	600
	L _{10h} = 30000 h	N	450
Moment of inertia of gearbox	16:1	kg cm ²	0.088
	40:1	kg cm ²	0.064
	60:1	kg cm ²	0.076
	120:1	kg cm ²	0.064
Continuous output torque ²⁾	16:1	Nm	44
	40:1	Nm	40
	60:1	Nm	44
	120:1	Nm	44
Maximum output torque ²⁾	16:1	Nm	70
	40:1	Nm	64
	60:1	Nm	70
	120:1	Nm	70

¹⁾ Value measured at a distance of 1 m, at no-load for a brushless DC motor speed of 3000 rpm and a reduction ratio of 5:1.

²⁾ Values given for an output shaft speed of 100 rpm in S1 mode (cyclic ratio = 1) on electrical machines for an ambient temperature of 30 °C.

³⁾ Force applied at mid-distance from the output shaft.

Order data			
Size	Reduction ratio	Reference	Weight kg
GBX 60	16:1, 40:1	GBX 060 ●●● ●●●●E	1.100
	60:1, 120:1		1.300

Order code GBX planetary gearboxes						
Size	Diameter of the housing	GBX	●●●	●●●	●●●●	E
		60 mm	060			
Reduction ratio		16:1		016		
		40:1		040		
		60:1		060		
		120:1		120		
Associated BDM brushless dc motor	Type	BDM72			DM72	
		BDM74			DM74	
		BDM75			DM75	
		BDM77			DM77	
BDM brushless dc drive adaptation						E

Dimensional drawings GBX planetary gearboxes

Mounting at motor side

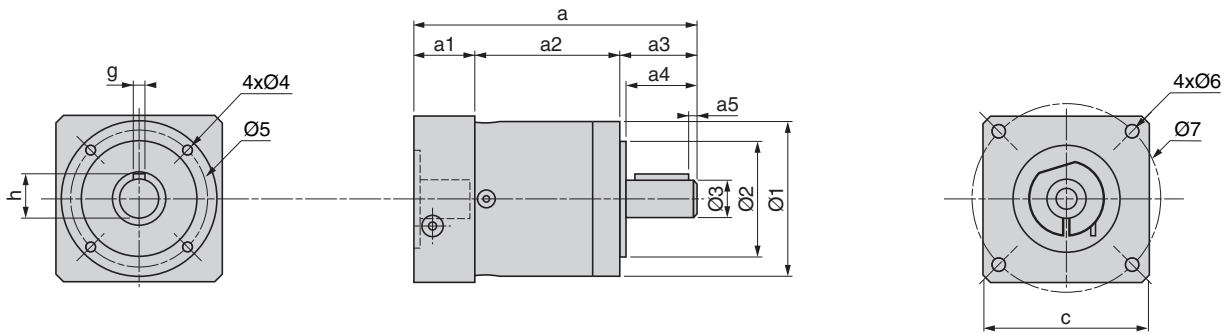

GBX	c	a	a1	a2	a3	a4	a5	h	g	Ø1	Ø2	Ø3	Ø4	Ø5	Ø6	Ø7
060 016 ... 040	60	118,5	24,5	59	35	30	2,5	16	5	60	40 h7	14 h7	M5 x 8	52	M4 x 10	73,5
060 060 ... 120	60	131,5	24,5	72	35	30	2,5	16	5	60	40 h7	14 h7	M5 x 8	52	M4 x 10	73,5

Mounting

Special tools are not required for mounting the GBX planetary gear. Note the following requirements:

- 1 Clean grease off contact areas and seals.
- 2 If possible, mount the motor in a vertical position. Fit motor into gearing.
- 3 Motor flange must be in contact with gearing flange. Tighten screws crosswise.
- 4 Tighten clamping ring with torque spanner.

More information can be found in the instructions supplied with the product.

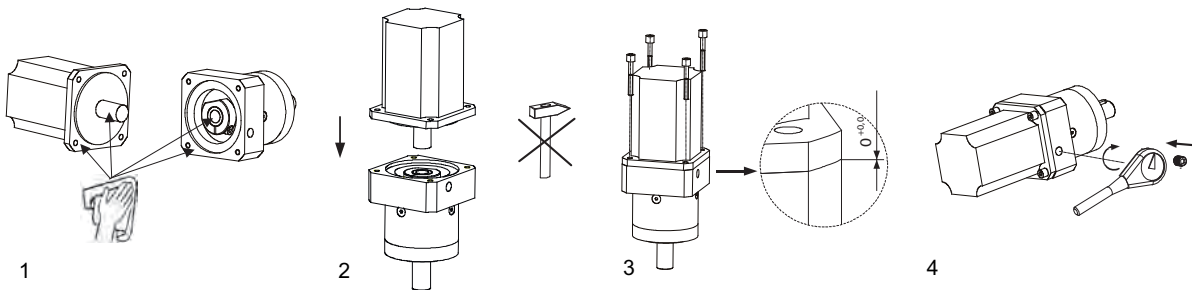

Conversion tables										
Rotor inertia										
	lb·in ²	lb·ft ²	lb·in·s ²	lb·ft·s ² slug·ft ²	kg·cm ²	kg·cm·s ²	g·cm ²	g·cm·s ²	oz·in ²	oz·in·s ²
lb·in ²	–	6.94 x 10 ⁻³	2.59 x 10 ⁻³	2.15 x 10 ⁻⁴	2.926	2.98 x 10 ⁻³	2.92 x 10 ³	2.984	16	4.14 x 10 ⁻²
lb·ft ²	144	–	0.3729	3.10 x 10 ⁻²	421.40	0.4297	4.21 x 10 ⁵	429.71	2304	5.967
lb·in·s ²	386.08	2.681	–	8.33 x 10 ⁻²	1.129 x 10 ³	1.152	1.129 x 10 ⁶	1.152 x 10 ³	6.177 x 10 ³	16
lb·ft·s ² slug·ft ²	4.63 x 10 ³	32.17	12	–	1.35 x 10 ⁴	13.825	1.355 x 10 ⁷	1.38 x 10 ⁴	7.41 x 10 ⁴	192
kg·cm ²	0.3417	2.37 x 10 ⁻³	8.85 x 10 ⁻⁴	7.37 x 10 ⁻⁶	–	1.019 x 10 ⁻³	1000	1.019	5.46	1.41 x 10 ⁻²
kg·cm·s ²	335.1	2.327	0.8679	7.23 x 10 ⁻²	980.66	–	9.8 x 10 ⁵	1000	5.36 x 10 ³	13.887
g·cm ²	3.417 x 10 ⁴	2.37 x 10 ⁻⁶	8.85 x 10 ⁻⁷	7.37 x 10 ⁻⁸	1 x 10 ⁻³	1.01 x 10 ⁻⁶	–	1.01 x 10 ⁻³	5.46 x 10 ⁻³	1.41 x 10 ⁻⁶
g·cm·s ²	0.335	2.32 x 10 ⁻³	8.67 x 10 ⁻⁴	7.23 x 10 ⁻⁵	0.9806	1 x 10 ⁻³	980.6	–	5.36	1.38 x 10 ⁻²
oz·in ²	0.0625	4.3 x 10 ⁻⁴	1.61 x 10 ⁻⁶	1.34 x 10 ⁻⁶	0.182	1.86 x 10 ⁻⁴	182.9	0.186	–	2.59 x 10 ⁻³
oz·in·s ²	24.3	0.1675	6.25 x 10 ⁻²	5.20 x 10 ⁻³	70.615	7.20 x 10 ⁻²	7.06 x 10 ⁴	72	386.08	–

Torque								
	lb·in	lb·ft	oz·in	Nm	kg·m	kg·cm	g·cm	dyne·cm
lb·in	–	8.333 x 10 ⁻²	16	0.113	1.152 x 10 ⁻²	1.152	1.152 x 10 ³	1.129 x 10 ⁶
lb·ft	12	–	192	1.355	0.138	13.825	1.382 x 10 ⁴	1.355 x 10 ⁷
oz·in	6.25 x 10 ⁻²	5.208 x 10 ⁻³	–	7.061 x 10 ⁻³	7.200 x 10 ⁻⁴	7.200 x 10 ⁻²	72.007	7.061 x 10 ⁴
Nm	8.850	0.737	141.612	–	0.102	10.197	1.019 x 10 ⁴	1 x 10 ⁷
kg·m	86.796	7.233	1.388 x 10 ³	9.806	–	100	1 x 10 ⁵	9.806 x 10 ⁷
kg·cm	0.8679	7.233 x 10 ⁻²	13.877	9.806 x 10 ⁻²	10 ⁻²	–	1000	9.806 x 10 ⁵
g·cm	8.679 x 10 ⁻⁴	7.233 x 10 ⁻⁵	1.388 x 10 ⁻²	9.806 x 10 ⁻⁵	1 x 10 ⁻⁵	1 x 10 ⁻³	–	980.665
dyne·cm	8.850 x 10 ⁻⁷	7.375 x 10 ⁻⁸	1.416 x 10 ⁻⁵	10 ⁻⁷	1.019 x 10 ⁻⁸	1.0197 x 10 ⁻⁶	1.019 x 10 ⁻⁶	–

Power		
	H.P.	W
H.P.	–	745.7
W	1.31 x 10 ⁻³	–

Length						
	in	ft	yd	m	cm	mm
in	–	0.0833	0.028	0.0254	2.54	25.4
ft	12	–	0.333	0.3048	30.48	304.8
yd	36	3	–	0.914	91.44	914.4
m	39.37	3.281	1.09	–	100	1000
cm	0.3937	0.03281	1.09 x 10 ⁻²	0.01	–	10
mm	0.03937	0.00328	1.09 x 10 ⁻³	0.001	0.1	–

Speed			
	1/min (1/min)	rad/sec	deg./sec
1/min (1/min)	–	0.105	6.0
rad/sec	9.55	–	57.30
deg./sec	0.167	1.745 x 10 ⁻²	–

Mass					
	lb	oz	slug	kg	g
lb	–	16	0.0311	0.453592	453.592
oz	6.35 x 10 ⁻²	–	1.93 x 10 ⁻³	0.028349	28.35
slug	32.17	514.8	–	14.5939	1.459 x 10 ⁴
kg	2.20462	35.274	0.0685218	–	1000
g	2.205 x 10 ⁻³	3.527 x 10 ⁻³	6.852 x 10 ⁻⁵	0.001	–

Temperature		
	°F	°C
°F	–	(9 - 32) x ⁵ / ₉
°C	9 ³ / ₄ ⁹ / ₅ + 32	–

Force					
	lb	oz	gf	dyne	N
lb	–	16	453.592	4.448 x 10 ⁵	4.4482
oz	0.0625	–	28.35	2.780 x 10 ⁴	0.27801
gf	2.205 x 10 ⁻³	0.03527	–	980.665	N.A.
dyne	2.248 x 10 ⁻⁶	3.59 x 10 ⁻⁶	1.02 x 10 ⁻³	–	0.0001
N	0.22481	3.5967	N.A.	100.000	–

Example for conversion:

Conversion of 10 inches to metres. Search for "in" (inches) in the left column of the "length" table and "m" (metres) in the header row. The table cell at the intersection of column and row shows the conversion factor: "0.0254". Multiply 10 inches by 0.0254 and the answer is the value in metres: 10 in x 0.0254 = 0.254 m.

